

K3i

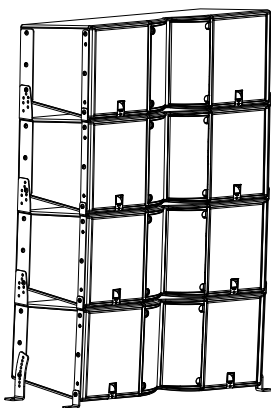

owner's manual (EN)

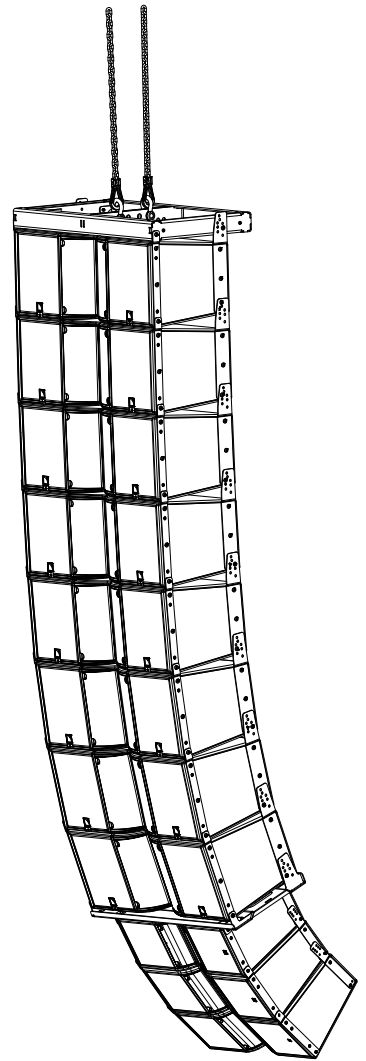
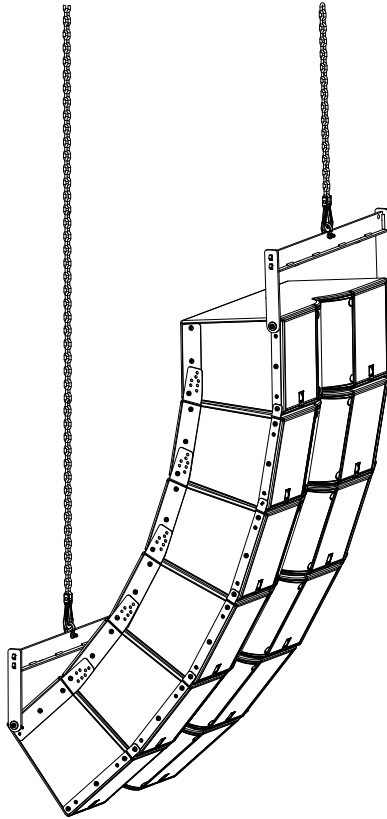
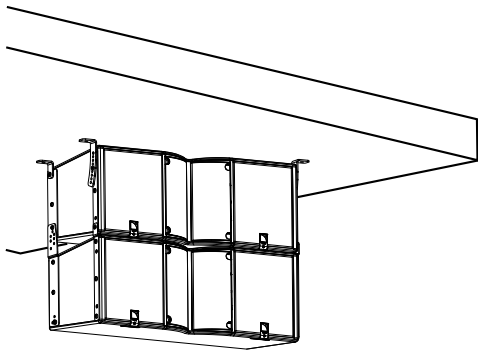

Document reference: K3i owner's manual (EN) version 3.1

Distribution date: September 5, 2022

© 2022 L-Acoustics. All rights reserved.

No part of this publication may be reproduced or transmitted in any form or by any means without the express written consent of the publisher.







Contents

Safety.....	5
Instructions.....	5
Introduction.....	7
K3i long throw line source for install.....	7
How to use this manual.....	7
Revision history.....	8
System components.....	8
System component illustrations.....	9
Electro-acoustical description.....	12
Adjustable fins.....	12
Directivity.....	15
Preset description.....	16
Connectors.....	17
Rigging system description.....	18
K3i.....	18
Rigging elements.....	20
K3i-BUMP.....	20
K3i-BAR.....	22
K3i-RIGBAR.....	23
KARAIi-DOWNK3i.....	25
K3i-TILTBRACKET.....	27
K3i-CEILINGBRACKET.....	29
K3i-SCREEN.....	30
Mechanical safety.....	31
Loudspeaker configurations.....	33
Line source.....	33
Line source with low-frequency element.....	34
Additional downfill element.....	36
Inspection and preventive maintenance.....	37
How to do preventive maintenance.....	37
Rigging part inspection.....	37
Mechanical system overview.....	38
K3i and Kara Ili with K3i-BAR and K3i-BUMP.....	39
K3i with K3i-RIGBAR and pullback.....	40

K3i ceiling-mounted with K3i-CEILINGBRACKET.....	41
K3i stacked on K3i-TILTBRACKET.....	41
Acoustical check.....	42
Enclosure check.....	42
Rigging procedures.....	46
General principles.....	46
Tools.....	48
Flying.....	49
Flying a K3i array with K3i-BUMP.....	49
Adding a pullback with K3i-RIGBAR.....	55
Rigging a Kara Ili downfill array under a K3i array with KARAIli-DOWNK3i.....	58
Ceiling-mounting a K3i array with K3i-CEILINGBRACKET.....	62
Stacking a K3i array on K3i-TILTBRACKET.....	67
Securing a screen.....	71
Connection to LA amplified controllers.....	72
Cabling.....	73
Corrective maintenance.....	77
Introduction.....	77
Tools and consumables.....	77
K3i.....	78
Exploded views.....	78
Disassembly and Reassembly procedures.....	80
Specifications.....	90
APPENDIX A: Recommendation for speaker cables.....	105
APPENDIX B: Specifications for custom rigging system.....	106

Safety

Instructions

-  **Inspect the system before any deployment.**
Perform safety related checks and inspections before any deployment.
- Perform preventive maintenance at least once a year.**
Refer to the preventive maintenance section for a list of actions and their periodicity.
Insufficient upkeep of the product can void the warranty.
- If any safety issue is detected during inspection, do not use the product before performing corrective maintenance.**
Check for issues. A rigging system part or fastener is missing or loose. A rigging system part exhibits: bends, breaks, broken parts, corrosion, cracks, cracks in welded joints, deformation, denting, wear, holes. A safety cue or label is missing.
-  **Never incorporate equipment or accessories not approved by L-Acoustics.**
-  **Read all the related PRODUCT INFORMATION documents shipped with the products before exploiting the system.**
-  **Do not store the product on an unstable cart, stand, tripod, bracket, or table.**
-  **Beware of sound levels.**
Do not stay within close proximity of loudspeakers in operation.
Loudspeaker systems are capable of producing very high sound pressure levels (SPL) which can instantaneously lead to permanent hearing damage to performers, production crew and audience members. Hearing damage can also occur at moderate level with prolonged exposure to sound.
Check the applicable laws and regulations relating to maximum sound levels and exposure times.
-  **Work with qualified personnel for rigging the system.**
Installation should only be carried out by qualified personnel that are familiar with the rigging techniques and safety recommendations outlined in this manual.
- Ensure personnel health and safety.**
During installation and set-up personnel must wear protective headgear and footwear at all times. Under no circumstances is personnel allowed to climb on a loudspeaker assembly.
- Respect the Working Load Limit (WLL) of third party equipment.**
L-Acoustics is not responsible for any rigging equipment and accessories provided by third party manufacturers. Verify that the Working Load Limit (WLL) of the suspension points, chain hoists and all additional hardware rigging accessories is respected.
- Respect the maximum configurations and the recommended safety precautions.**
For safety issue, respect the maximum configurations outlined in this manual. To check the conformity of any configuration in regards with the safety precautions recommended by L-Acoustics, model the system in Soundvision and refer to the warnings in Mechanical Data section.
- Be cautious when flying a loudspeaker configuration.**
Before installing/raising the product, check each individual element to make sure that it is securely fastened to the adjacent element. Always verify that no one is standing underneath the product when it is being installed/raised. Never leave the product unattended during the installation process.
As a general rule, L-Acoustics recommends the use of secondary safety at all times.
- Be cautious when ground-stacking a loudspeaker array.**
Do not stack the loudspeaker array on unstable ground or surface. If the array is stacked on a structure, platform, or stage, always check that the latter can support the total weight of the array.
As a general rule, L-Acoustics recommends the use of safety straps at all times.

Risk of falling objects

Verify that no unattached items remain on the product or assembly.

Risk of tipping

Remove all rigging accessories before transporting a product or an assembly.

Take into account the wind effects on dynamic load.

When a loudspeaker assembly is deployed in an open air environment, wind can produce dynamic stress to the rigging components and suspension points.

If the wind force exceeds 6 bft (Beaufort scale), lower down and/or secure the product or the assembly.

**Intended use**

This system is intended for use by trained personnel for professional applications.



As part of a continuous evolution of techniques and standards, L-Acoustics reserves the right to change the specifications of its products and the content of its documents without prior notice.

Check www.l-acoustics.com on a regular basis to download the latest document and software updates.

**Long term exposure to extreme conditions may damage the product.**

For more information, refer to the **Products weather protection** document, available on the website.

**Read the maintenance section of this document before servicing the product.****Contact L-Acoustics for advanced maintenance.**

Any unauthorized maintenance operation will void the product warranty.



This marking indicates that this product should not be disposed of with other household waste throughout the EU. To prevent possible harm to the environment or human health from uncontrolled waste disposal, recycle it responsibly to promote the sustainable reuse of material resources. To return your used device, please use the return and collection systems or contact the retailer where the product was purchased. They can take this product for environmentally safe recycling.



Introduction

K3i long throw line source for install

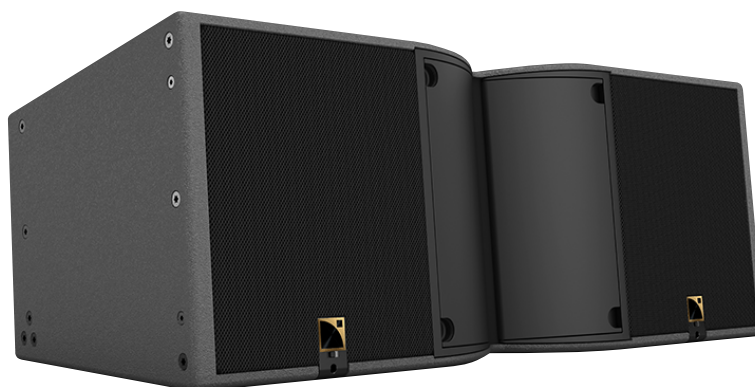

K3i is the installation version of K3, designed for long-throw installation applications. K3i shares identical sonic performance with its touring counterpart but features a sleeker design and streamlined mounting hardware fitting integration requirements.

Housing the internationally recognized K2 performance into a compact enclosure, K3i is ideal for medium to large-scale venues that require premium-tour sound and limited footprint, such as large concert halls, clubs, congress centers and sport venues.

Inter-element angles and Panflex™ for user-adjustable horizontal directivity enable integrators, consultants and sound designers to precisely tailor the array coverage to any audience geometry.

Requiring only two channels of amplification, K3i is a high value solution that provides large-format concert sound in compact and lightweight construction to facilitate most integration scenarios. K3i is highly weather-resistant as standard and can be color-matched to melt into any venue decor, indoor or outdoor.

How to use this manual

The K3i owner's manual is intended for all actors involved in the system design, implementation, preventive and corrective maintenance of the K3i system. It must be used as follows:

1. Read the technical description for an overview of all system elements, their features, and their compatibilities.
 - [Electro-acoustical description](#) (p.12)
 - [Rigging system description](#) (p.18)
2. Prepare the system configuration. Consider the mechanical limits and the available acoustical configurations.
 - [Mechanical safety](#) (p.31)
 - [Loudspeaker configurations](#) (p.33)
3. Before rigging the system, perform mandatory inspections and functional checks.
 - [Inspection and preventive maintenance](#) (p.37)
4. To deploy the system, follow the step-by-step rigging instructions and refer to the cabling schemes.
 - [Rigging procedures](#) (p.46)
 - [Connection to LA amplified controllers](#) (p.72)



The [Corrective maintenance](#) (p.77) section contains the operations authorized for the end user. Performing another operation exposes to hazardous situations. For advanced maintenance, contact your L-Acoustics representative.

As part of a continuous evolution of techniques and standards, L-Acoustics reserves the right to change the specifications of its products and the content of its document without prior notice. Please check www.l-acoustics.com on a regular basis to download the latest document and software updates.

Contact information

For information on advanced corrective maintenance:

- contact your Certified Provider or your L-Acoustics representative
- for Certified Providers, contact the L-Acoustics customer service: customer.service@l-acoustics.com (EMEA/APAC), laus.service@l-acoustics.com (Americas).

Symbols

The following symbols are used in this document:

 This symbol indicates a potential risk of harm to an individual or damage to the product. It can also notify the user about instructions that must be strictly followed to ensure safe installation or operation of the product.

 This symbol notifies the user about instructions that must be strictly followed to ensure proper installation or operation of the product.

 This symbol notifies the user about complementary information or optional instructions.

Revision history

version number	publication date	modification
1.0	Apr. 2021	Initial version.
2.0	Dec. 2021	<ul style="list-style-type: none"> • Updated the maximum limit for pullback configurations following the release of Soundvision 3.6. See Mechanical safety (p.31) • Added the Inspection and preventive maintenance (p.37). • Added the Corrective maintenance (p.77).
3.0	Jul. 2022	<ul style="list-style-type: none"> • Added safe limit to pullback configurations in Mechanical safety (p.31). • Updated D/R - HF diaphragm (p.87). • Updated APPENDIX B: Specifications for custom rigging system (p.106) to add the center of gravity.
3.1	Sep. 2022	Updated APPENDIX B: Specifications for custom rigging system (p.106).

System components

Loudspeaker enclosures

K3i	2-way active WST [®] enclosure: 2 x 12" LF + 4" HF diaphragm (installation version)
Kara Ili	2-way active WST [®] enclosure: 2 x 8" LF + 3" HF diaphragm (installation version)
KS28	Flyable subwoofer 2 x 18"
KS21i	High power compact subwoofer: 1 x 21" (installation version)

Powering and driving system

LA4X / LA8 / LA12X Amplified controller with DSP, preset library and networking capabilities

 Refer to the LA4X / LA8 / LA12X owner's manual for operating instructions.

Cables

4 x 2.5 mm² cable speaker cable with bare wire endings

	Adapt the cable length to the installation.
2 x 2.5 mm ² cable	speaker cable with bare wire endings
	Adapt the cable length to the installation.
custom 4-point speakON cable	4-point speakON cable (2.5 mm ² gauge) to bare wire cable
	This cable needs to be custom made.

i **Information about the connection of the enclosures to the LA amplified controllers is given in this document.**

Refer to the LA4X / LA8 / LA12X owner's manual for detailed instructions about the whole cabling scheme, including modulation cables and network.

Rigging elements

K3i-TILTBRACKET	Fastening bracket with angles for K3i
K3i-CEILINGBRACKET	Ceiling fastening bracket with angles for K3i
K3i-LINK	Rigging plate for K3i
K3i-ENDLINK	End rigging plate for K3i
K3i-BUMP	Flying frame for K3i
K3i-BAR	Extension bar for K3i-BUMP
K3i-RIGBAR	Rigging bar and pullback for K3i
KARAIi-DOWNK3i	Interface for flying Kara Ili below K3i
CLAMP250	Clamp certified for 250 kg

Screens

K3i-SCREEN	Acoustically transparent front screen for K3i
------------	---

Software applications

Soundvision	3D acoustical and mechanical modeling software
LA Network Manager	Software for remote control and monitoring of amplified controllers

i Refer to the **Soundvision** help.
Refer to the **LA Network Manager** help.

System component illustrations

Cables



4 x 2.5 mm² cable

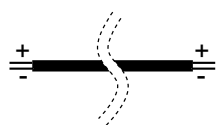

2 x 2.5 mm² cable

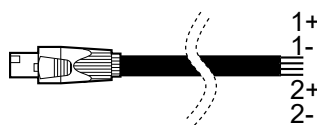

custom 4-point speakON cable

Rigging accessories

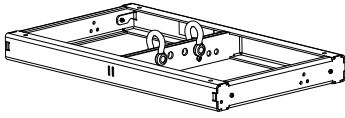

K3i-BUMP

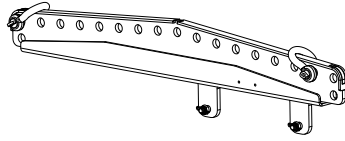

K3i-BAR

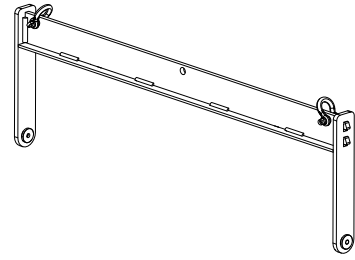

K3i-RIGBAR

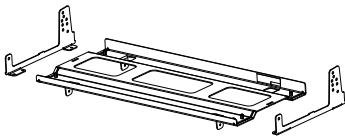

KARAIi-DOWNK3i

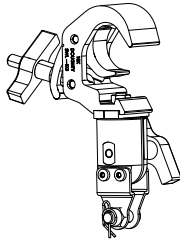

CLAMP250

Rigging plates

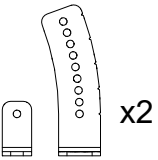

K3i-TILTBRACKET

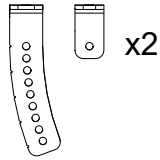

K3i-CEILINGBRACKET

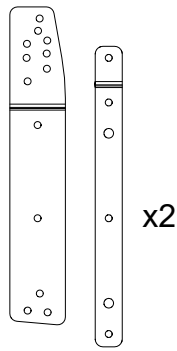

K3i-LINK

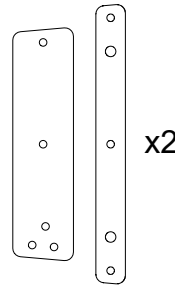

K3i-ENDLINK

Screens

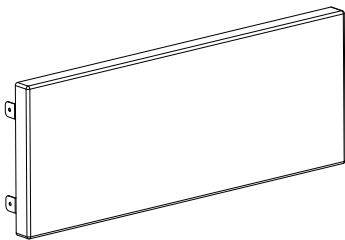

K3i-SCREEN

Software applications

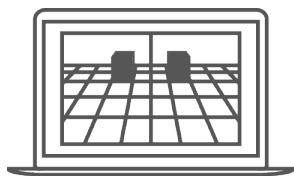

Soundvision



LA Network Manager

Electro-acoustical description

Adjustable fins

The K3i enclosure features an adjustable horizontal directivity system. Using the adjustable fins, horizontal directivity can be adjusted with four different settings: 70° / 110° symmetric or 90° asymmetric. A specific K3i preset must be used for each directivity setting.

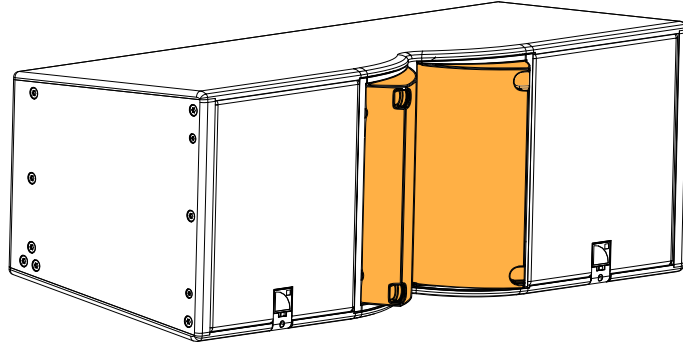

Within a line source, different directivity settings can be combined to improve the coverage of the audience geometry.

70° setting (preset [K3 70])

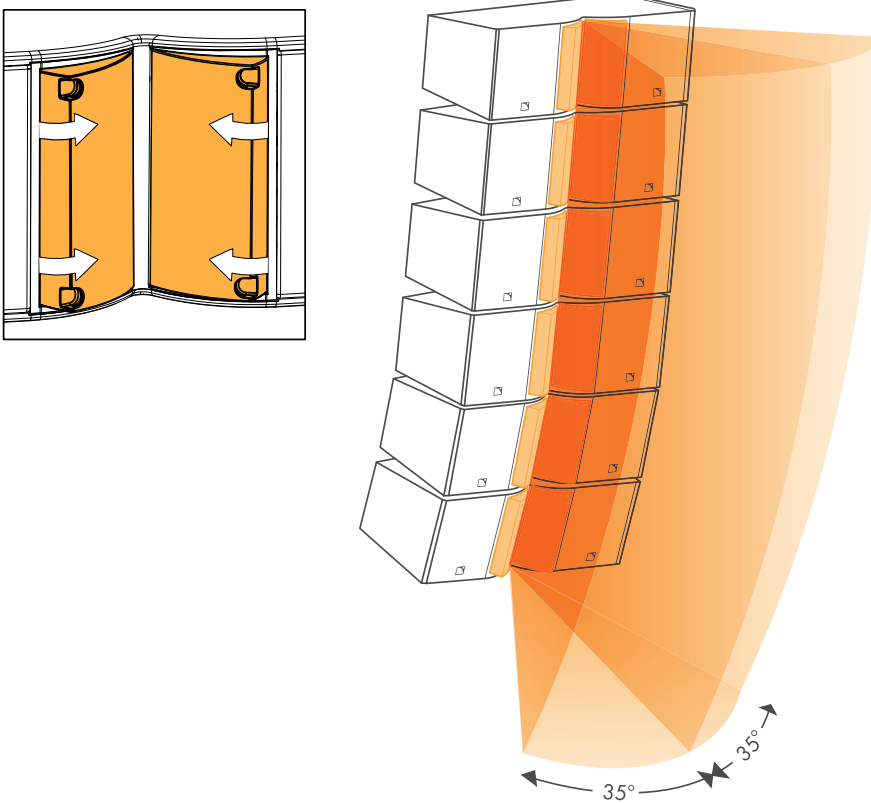

Set the fins in the 70° position to provide the system with a 2 dB on-axis gain (> 1 kHz), compared to the 110° setting.

90° settings (preset [K3 90])

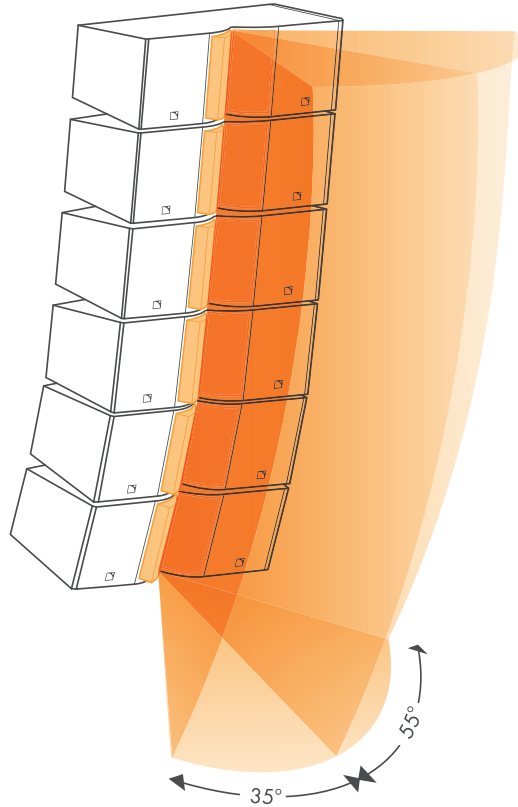
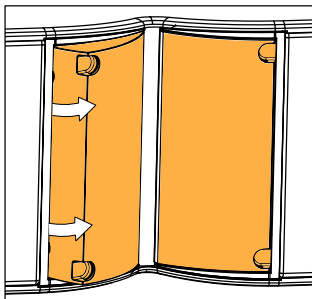
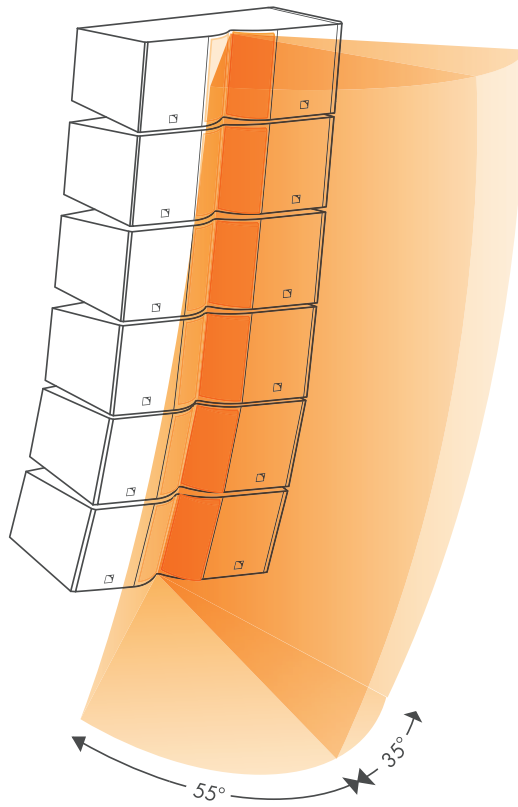
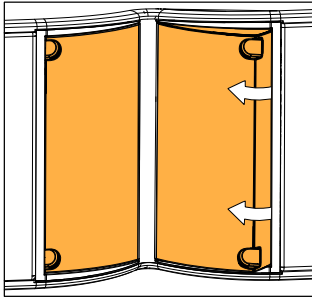

110° setting (preset [K3 110])

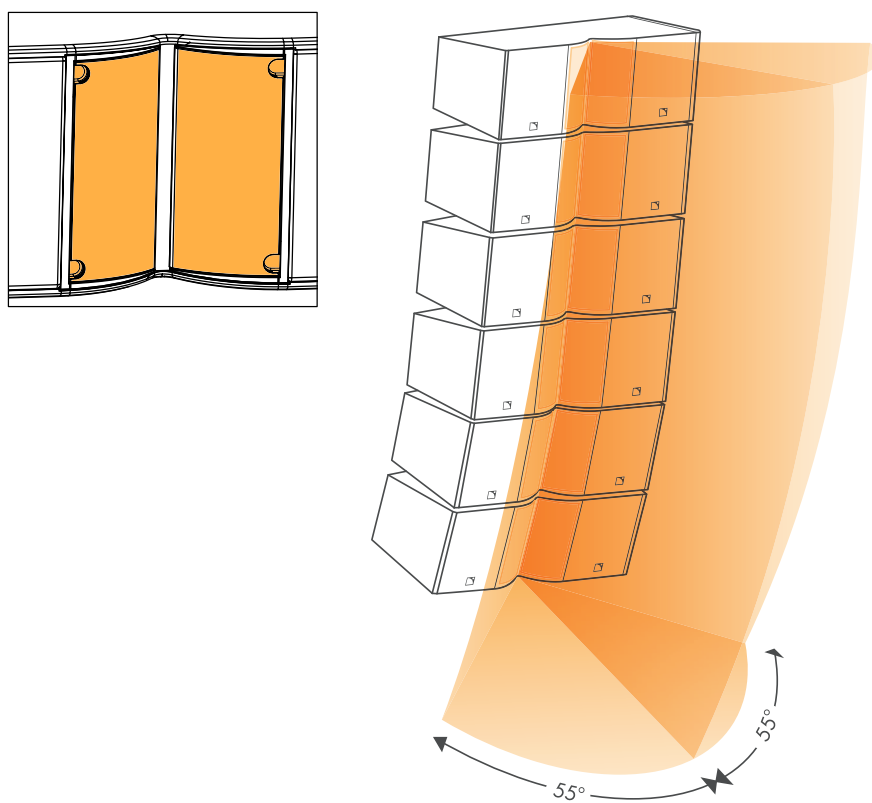

Mixed settings

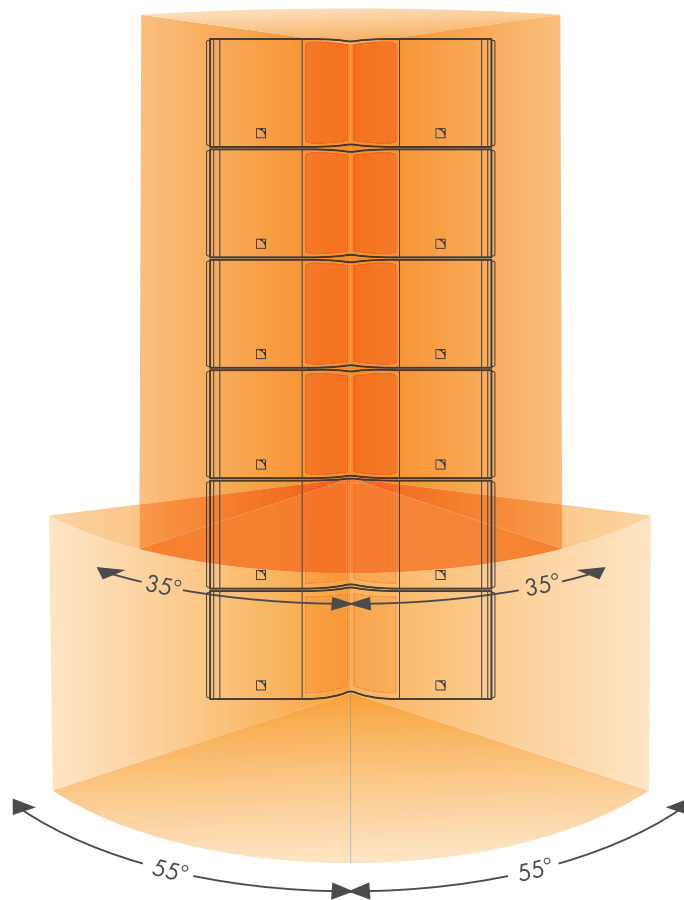

Directivity

Horizontal

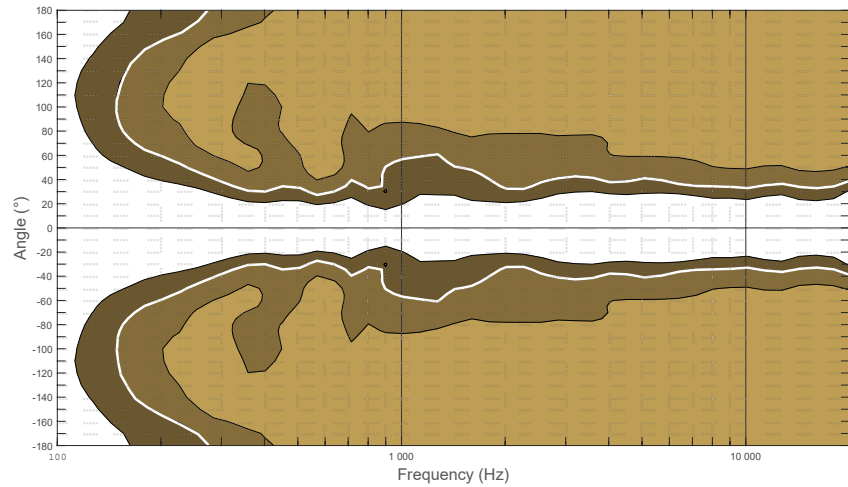
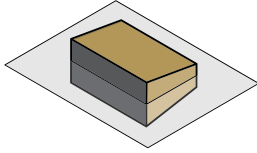

Dispersion angle diagram of a K3i array with 70° fins setting, using lines of equal sound pressure at -3 dB, -6 dB, -12 dB.

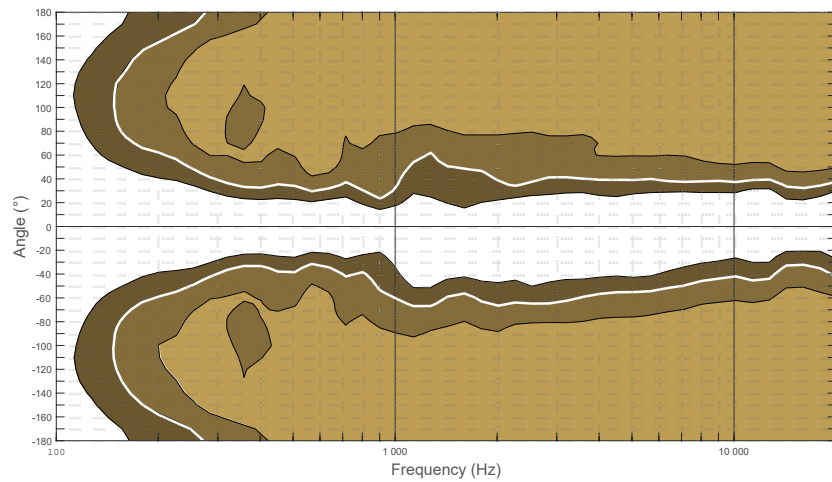
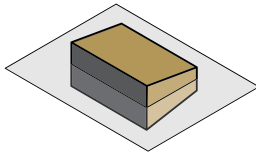

Dispersion angle diagram of a K3i array with 90° fins setting, using lines of equal sound pressure at -3 dB, -6 dB, -12 dB.

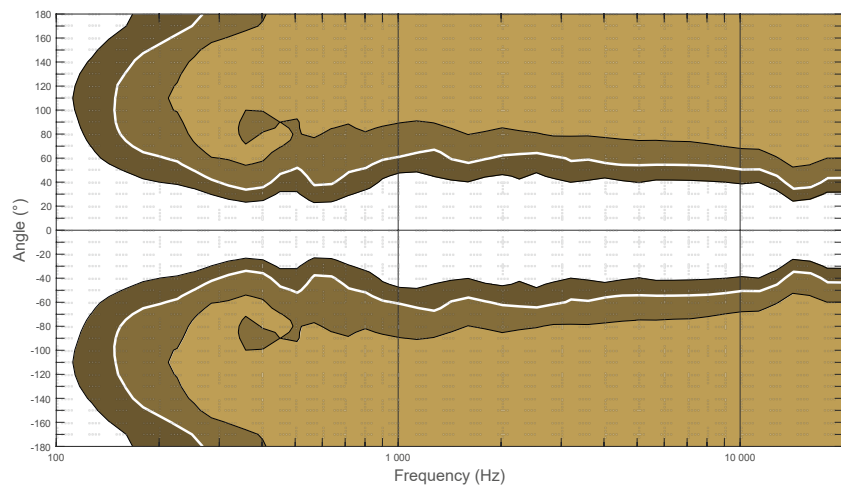
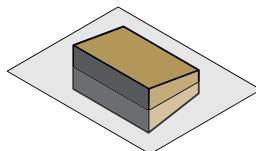

Dispersion angle diagram of a K3i array with 110° fins setting, using lines of equal sound pressure at -3 dB, -6 dB, -12 dB.

Preset description

[K3 70] [K3 90] [K3 110] [KARAIIDOWNK3]

loudspeaker elements	outputs	channels	routing	gain	delay	polarity	mute
LF	OUT 1	LF	IN A	0 dB	0 ms	+	ON
HF	OUT 2	HF					ON
LF	OUT 3	LF	IN A	0 dB	0 ms	+	ON
HF	OUT 4	HF					ON

[KS28_60] [KS21_60]

outputs	channels	routing	gain	delay	polarity	mute
OUT 1	SB	IN A	0 dB	0 ms	+	ON
OUT 2	SB	IN A	0 dB	0 ms	+	ON
OUT 3	SB	IN A	0 dB	0 ms	+	ON
OUT 4	SB	IN A	0 dB	0 ms	+	ON

[KS28_60_C] [KS28_60_Cx] [KS21_60_C] [KS21_60_Cx]

loudspeaker elements	outputs	channels	routing	gain	delay	polarity	mute
SR	OUT 1	SR	IN A	0 dB	0 ms	+	ON
SB	OUT 2	SB					ON
SB	OUT 3	SB					ON
SB	OUT 4	SB					ON

Connectors

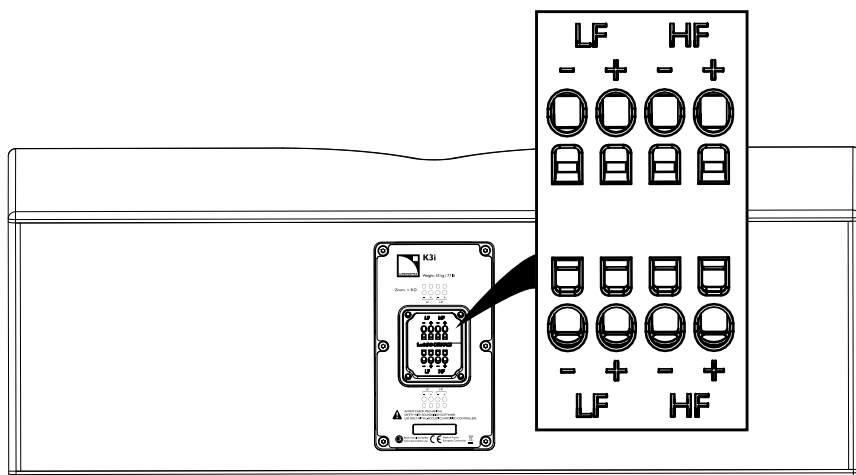

K3i

2 x 4-point terminal blocks with push-in connection

Internal pinout for L-Acoustics 2-way active enclosures

Terminal block points	1 +	1 -	2 +	2 -
Transducer connectors	LF +	LF -	HF +	HF -

Rigging system description

K3i

The K3i system is the installation version of the K3 system and features a simplified rigging system to optimize visual impact.

The enclosures are assembled together with rigging plates and rigging accessories suited for installation. Like the K3 system, the enclosures can be deployed in flown or stacked arrays. Multiple rigging kits are available depending on the desired configuration (refer to [System component illustrations](#) (p.9)).

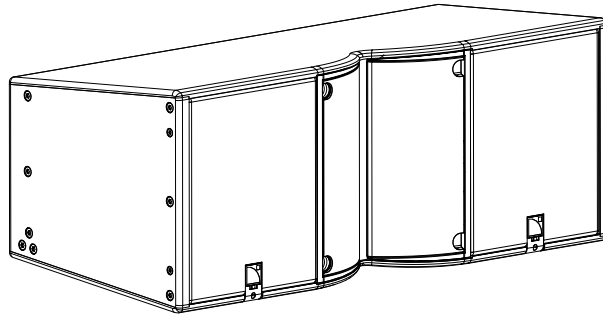

K3i is compatible with two types of rigging plate kits:

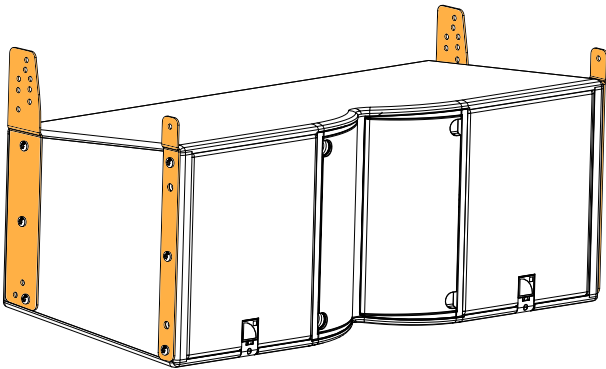

standard rigging plates (K3i-LINK)

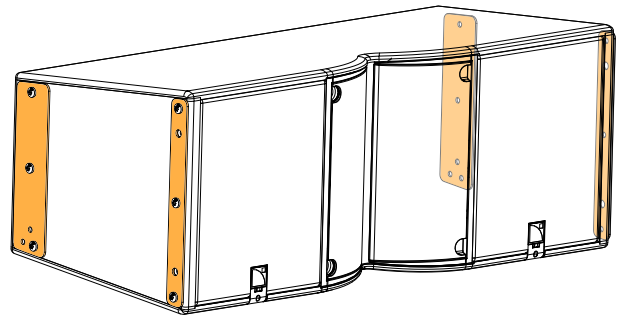

end rigging plates (K3i-ENDLINK)

K3i-LINK can be used to add an inter-element angle of 0.25°, 1°, 2°, 3°, 4°, 5°, 7.5° or 10° between two K3i.

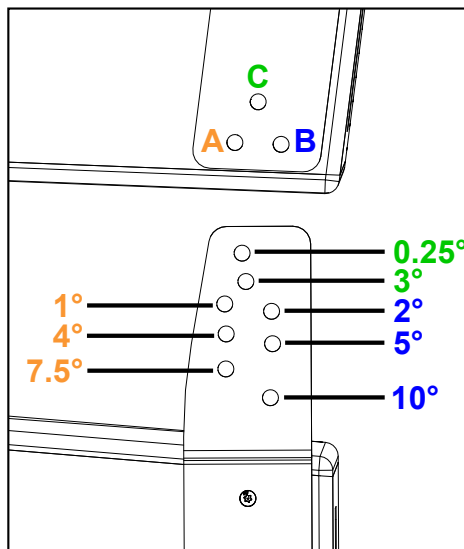

K3i features on each side:

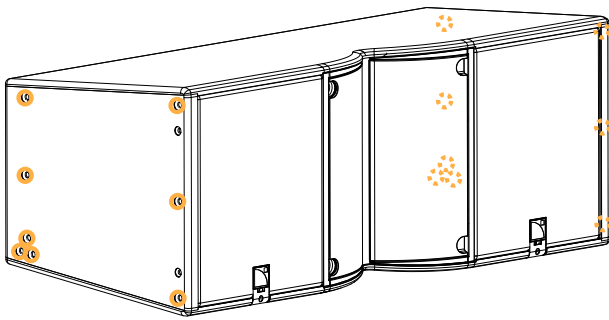

Eight M8 inserts for flown configurations with a rigging frame or stacked configurations.

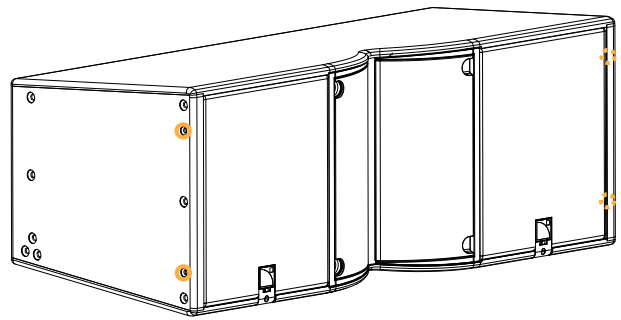

Two M6 inserts for securing a screen.

All inserts are fitted with placeholder screws. Leave the placeholder screws in the inserts that are not used.

The three inserts at the bottom rear on each side are used depending on the rigging accessory secured under the enclosure, and on the inter-element angle.

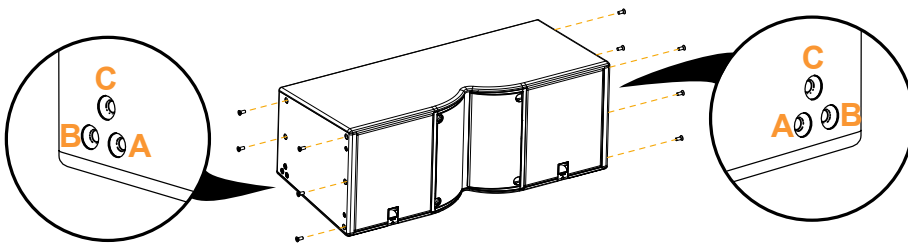

! Risk of acoustic leaks

Do not remove the placeholder screws from the bottom rear inserts (A, B or C) that are not used.

rigging accessory	inter-element angles	used insert
K3i-LINK (connecting from an enclosure below) / KARAlli-DOWNK3i	0.25°, 3°	C
	2°, 5°, 10°	B
	1°, 4°, 7.5°	A
K3i-RIGBAR	—	B
K3i-TILTBRACKET	5°, 2.5°, 0°, -2.5°, -5°, -7.5°, -10°, -12.5°, -15°	A

It is recommended to use the rigging report from Soundvision to prepare the enclosures.

! Rigging screws

Only use the rigging screws provided by L-Acoustics.
Do not use the placeholder screws for rigging.

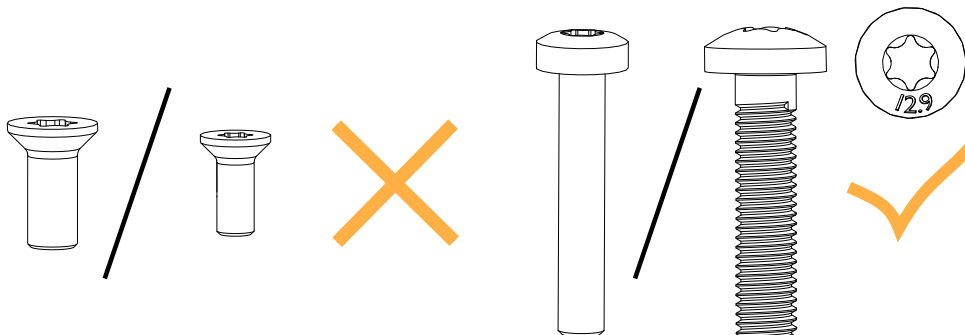

! Always put the placeholder screws back in place to avoid leaks.

Rigging elements

K3i-BUMP

K3i-BUMP is a rigging frame designed for flying K3i.

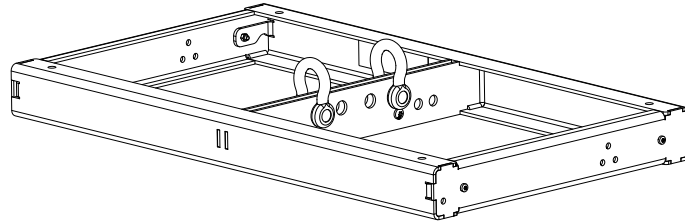

K3i-BUMP can be used as the main lifting accessory for flying arrays of K3i.

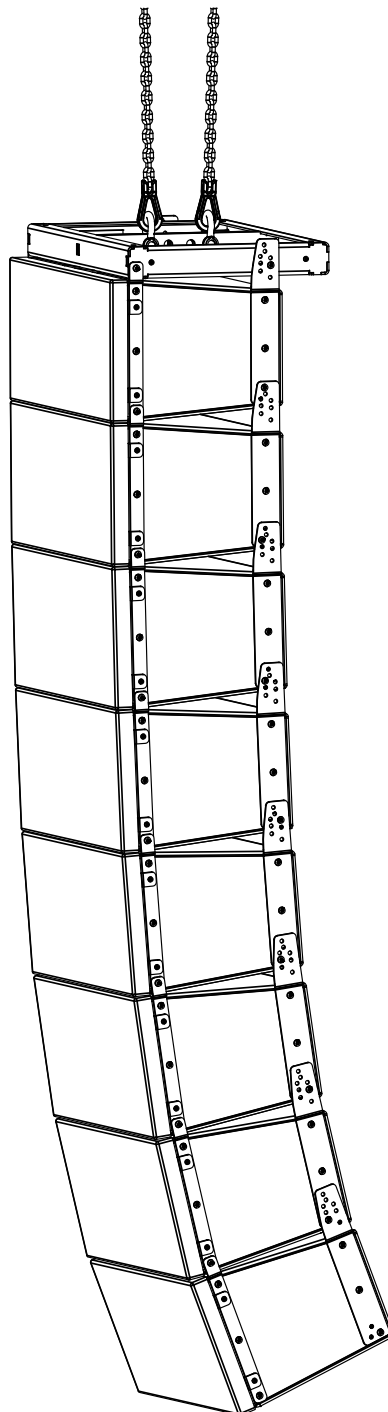

K3i-BUMP is secured to the array with four M8x35 rigging screws and M8 nuts (provided). With K3i-LINK, the splay angle with K3i can be set to 0°, 2.5°, 5°.

i To calculate the site angle of the first enclosure, subtract the splay angle from the site angle of K3i-BUMP.

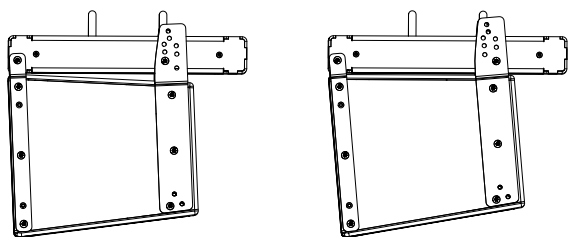

2.5° splay angle	5° splay angle
0° K3i-BUMP site angle	0° K3i-BUMP site angle
0-2.5 = -2.5° K3i site angle	0-5 = -5° K3i site angle

In Soundvision, the splay angles are labeled as follows (**Elements** panel):

angle in Soundvision	splay angle
5°	0°
7.5°	2.5°
10°	5°

! It is recommended to set a 0° splay angle (5° in Soundvision) between the first K3i and K3i-BUMP. By doing this, the K3i axis is parallel to K3i-BUMP.

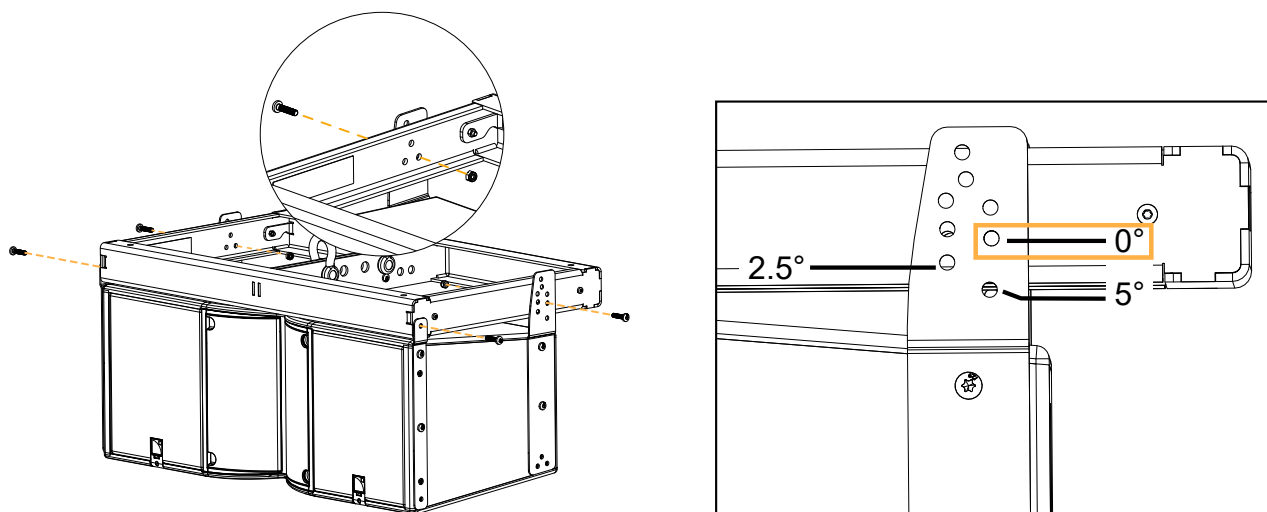

Four holes are available on the central bar of the K3i-BUMP for site angle adjustments. Four additional holes are available to add K3i-BAR to K3i-BUMP as an extension to increase the site angle.

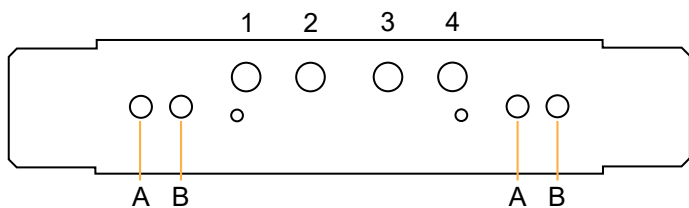

K3i-BAR

K3i-BAR can be attached to the K3i-BUMP with two Ø25 mm rigging axes, M12 nuts, and safety pins.

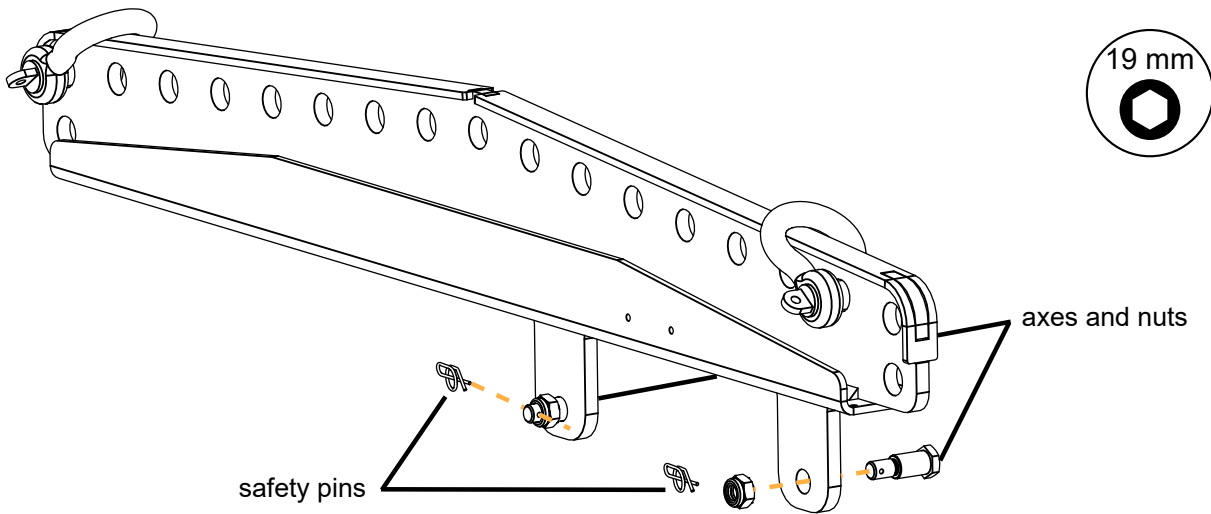

Seventeen (17) holes are available on the K3i-BAR, which can be attached as a rear or a front extension and in position A or B, thus offering a total of 68 discrete positions for pick-up points. The pick-up points are compatible with Ø19 mm shackles WLL 3.25 t (two provided).

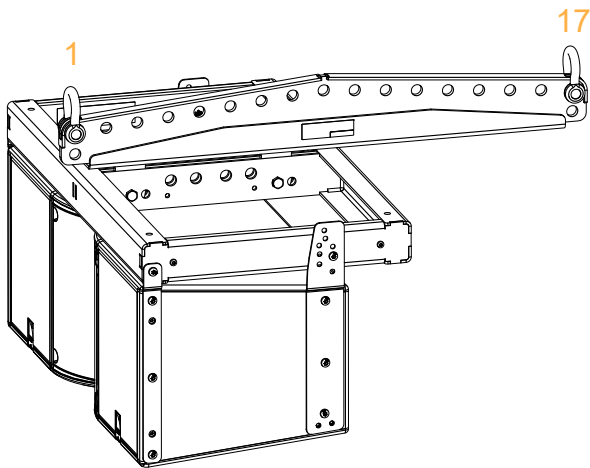

rear extension

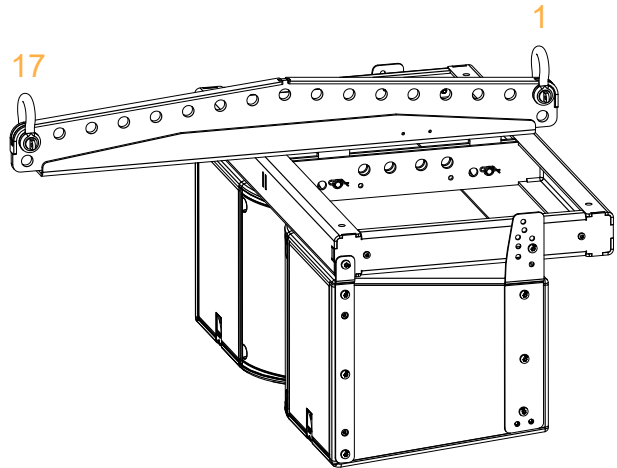

front extension

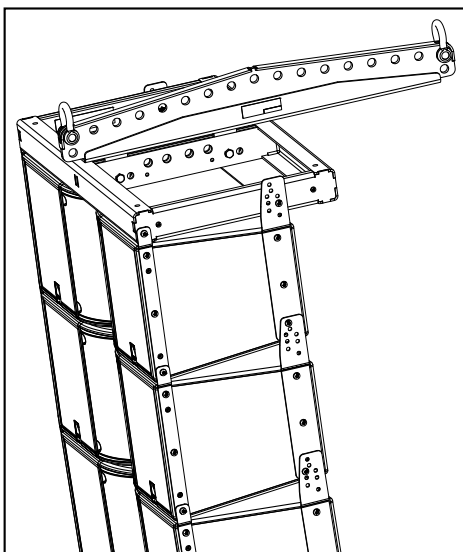

The rear extension is suited to downwards site angles, and pullbacks.

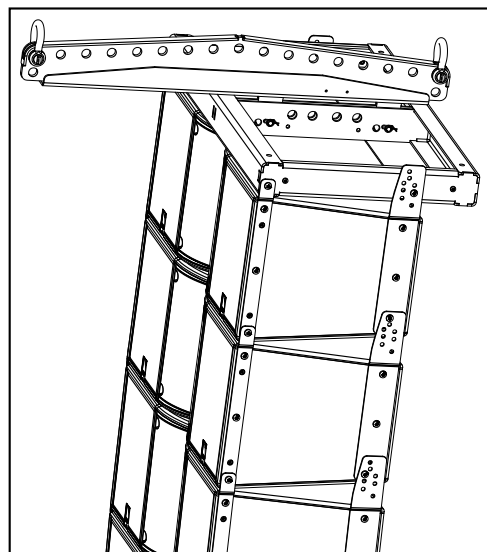

The front extension is suited to upwards site angles.

K3i-RIGBAR

Secured at the bottom of the array, K3i-RIGBAR can be used as a pullback either with K3i-BUMP combined with K3i-BAR or another K3i-RIGBAR as the main lifting accessory, to provide a lightweight solution for flying up to 16 K3i.

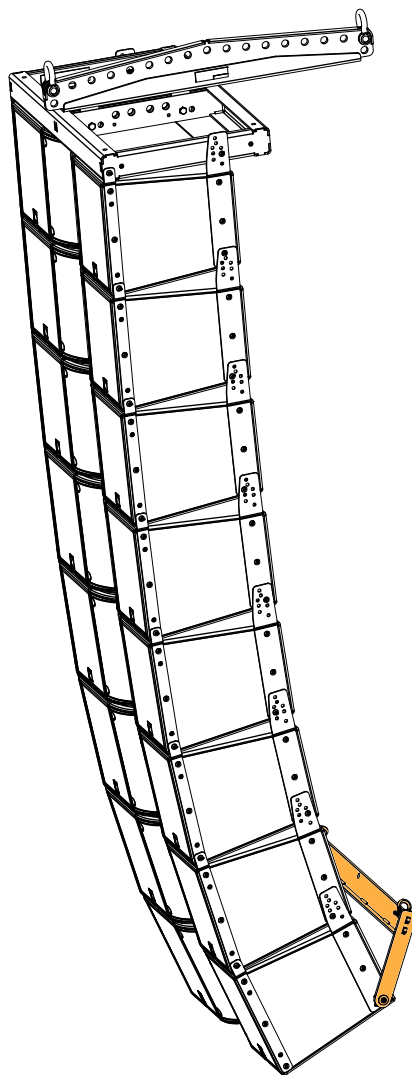
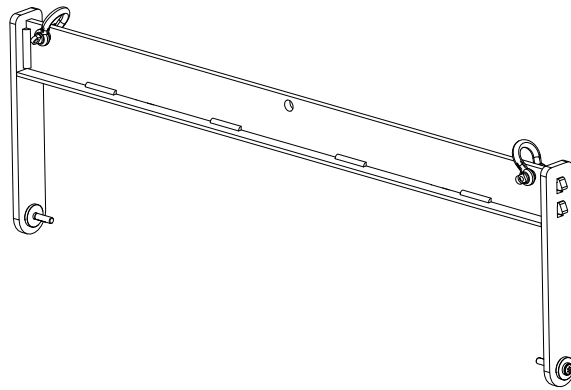

K3i-RIGBAR is equipped with two Ø12 mm shackles WLL 1 t.

With K3i-RIGBAR as the main lifting accessory, K3i-ENDLINK is required on the top enclosure.

i Secure K3i-RIGBAR at the front for a positive initial site angle.

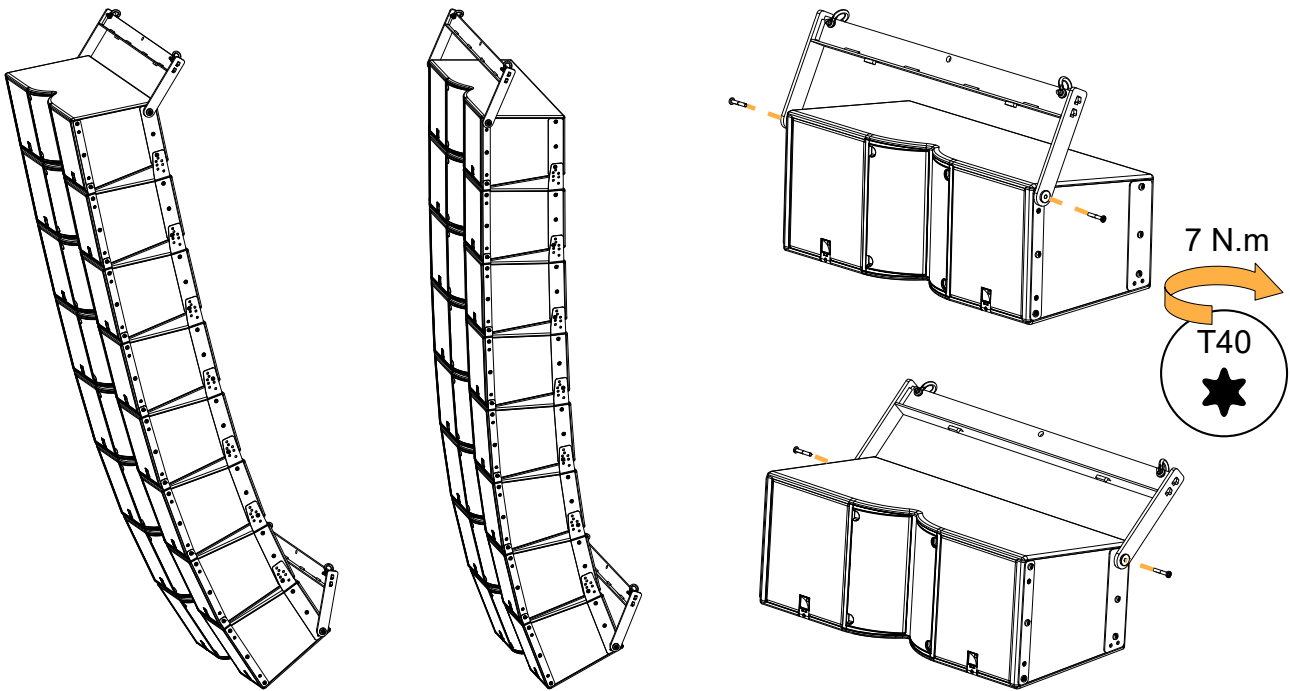

With K3i-RIGBAR as the main lifting accessory, CLAMP250 can be used to hang an array from a truss. If a pullback is implemented, CLAMP250 cannot be used on the bottom K3i-RIGBAR. Refer to the **CLAMP250 owner's manual** for more information.

! Maximum limit with CLAMP250

CLAMP250 has a WLL (Working Load Limit) of 250 kg / 550 lb. It can support an array of up to 6 K3i. For an hybrid array, check the total weight of the array in Soundvision.

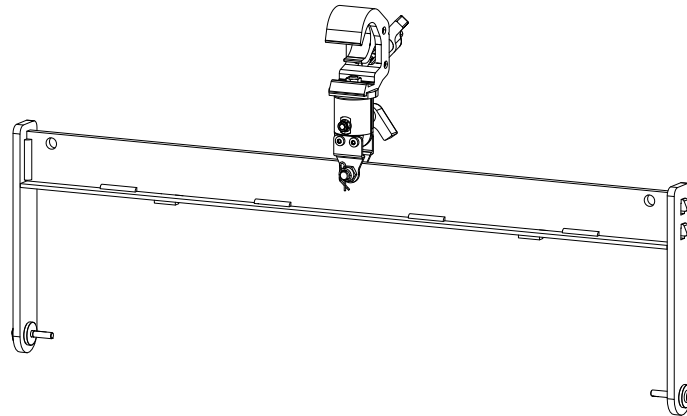

! When using K3i-RIGBAR as the main lifting accessory, always implement a secondary safety using available holes.

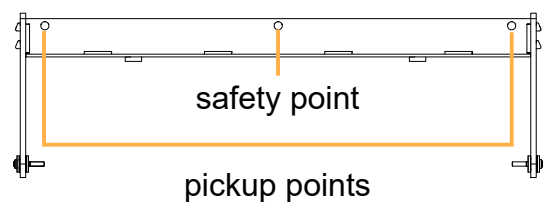
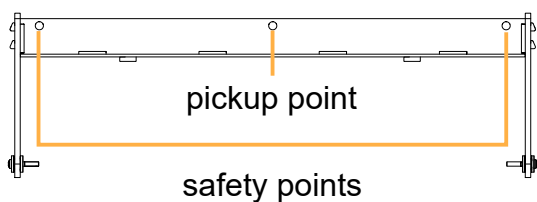

KARAlli-DOWNK3i

KARAlli-DOWNK3i is a rigging interface for a Kara Ili array under a K3i array.

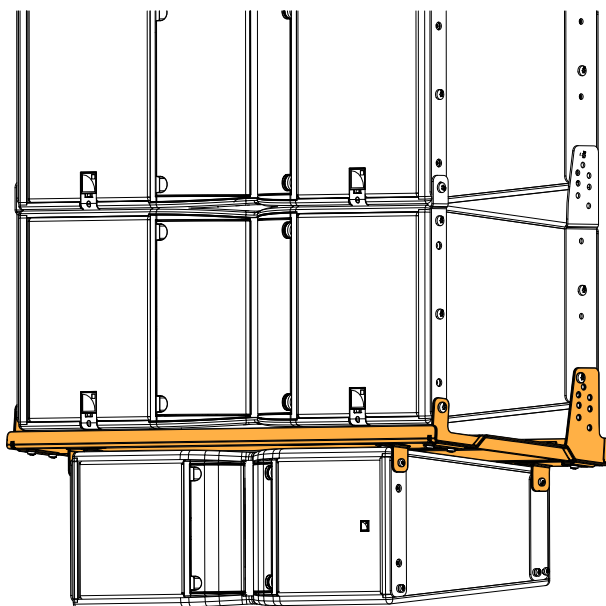
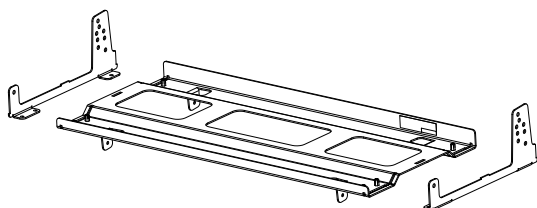

The inter-element angle between the K3i array and the Kara Ili array can be set to 0.25°, 1°, 2°, 3°, 4°, 5°, 7.5°, or 10°.

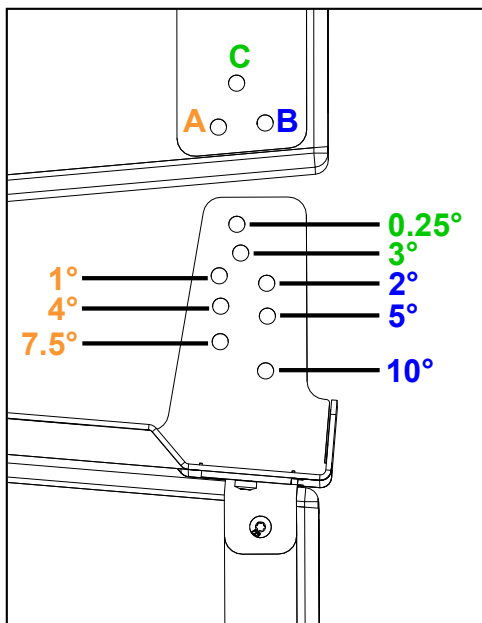

KARAli-DOWNK3i is assembled with six M6x19 screws (provided).

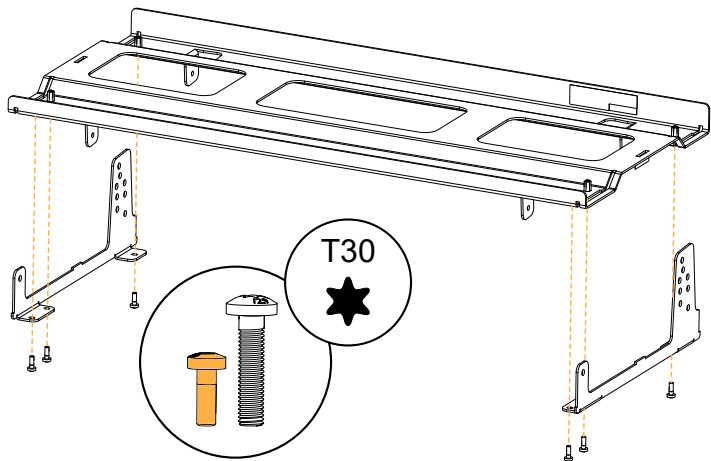

KARAli-DOWNK3i is secured to the K3i array with four M8x35 screws, and to the Kara Ili array with four M6x19 screws (provided).

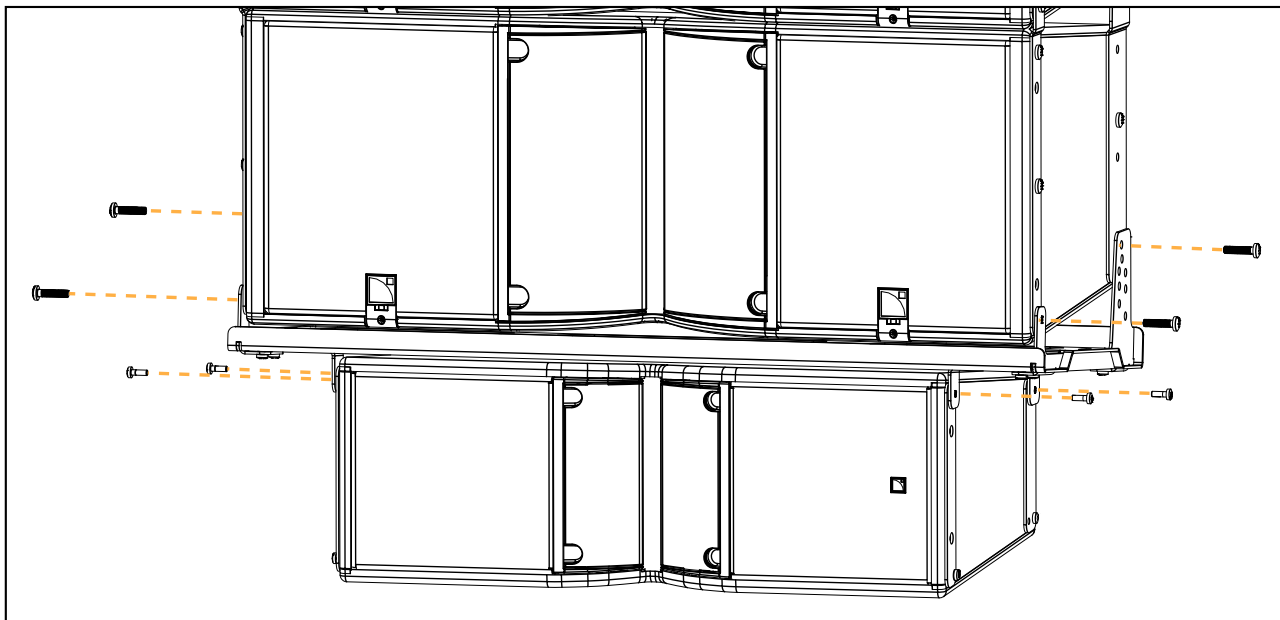

K3i-TILTBRACKET

K3i-TILTBRACKET is a set of four fastening brackets with site angle adjustment for improved stability on a stack of K3i.

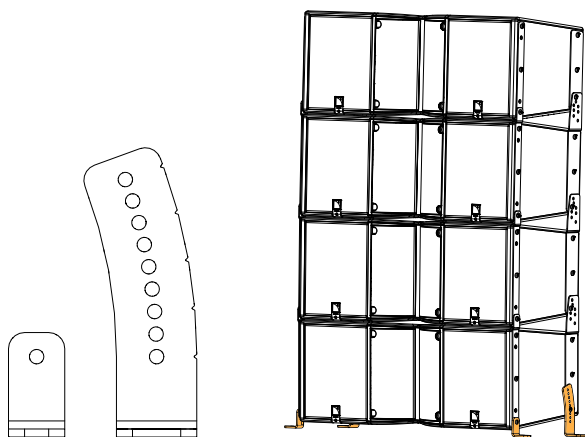

K3i-ENDLINK is required on the top enclosure.

The angles can be set at the rear for downwards site angles or the front for upwards site angles. Using K3i-TILTBRACKET at the rear, the site angle can be set between 5° and -15° in 2.5° steps.

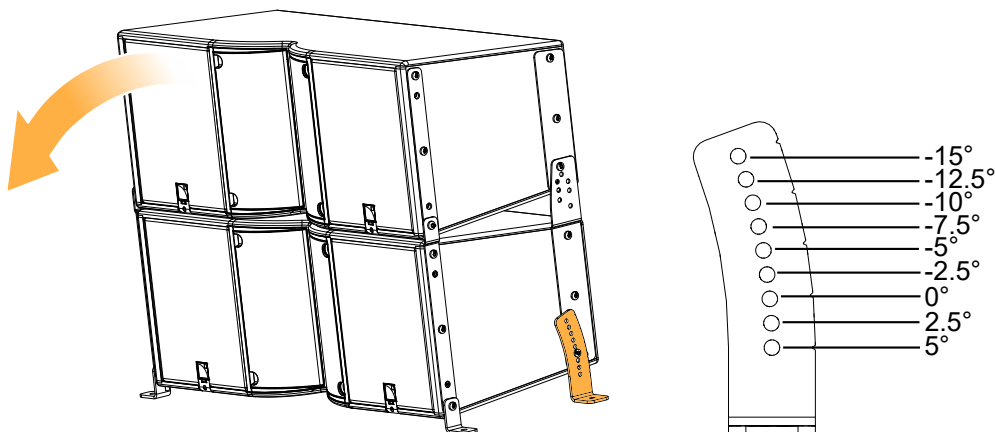

Using K3i-TILTBRACKET at the front, the site angle can be set between 5° and 25° in 2.5° steps.

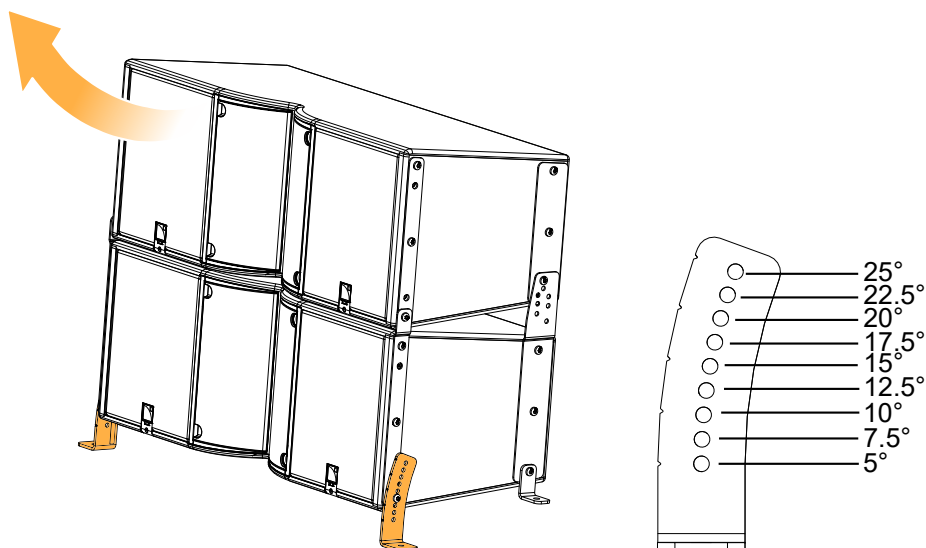

When used at the front, it is not possible to use K3i-SCREEN.

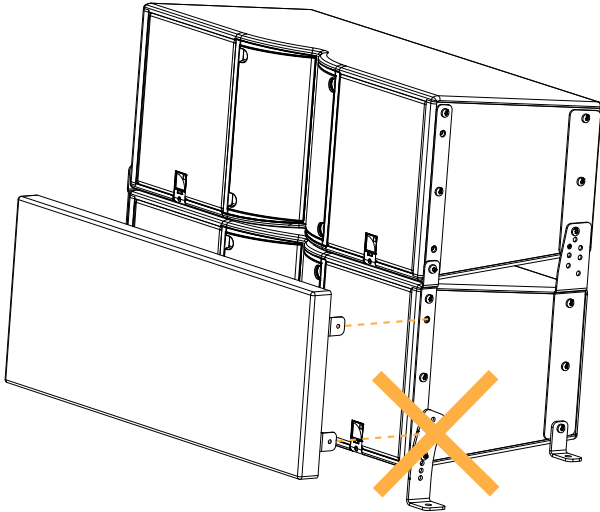

K3i-TILTBRACKET cannot be used to mount K3i under the ceiling. Refer to [K3i-CEILINGBRACKET](#) (p.29).

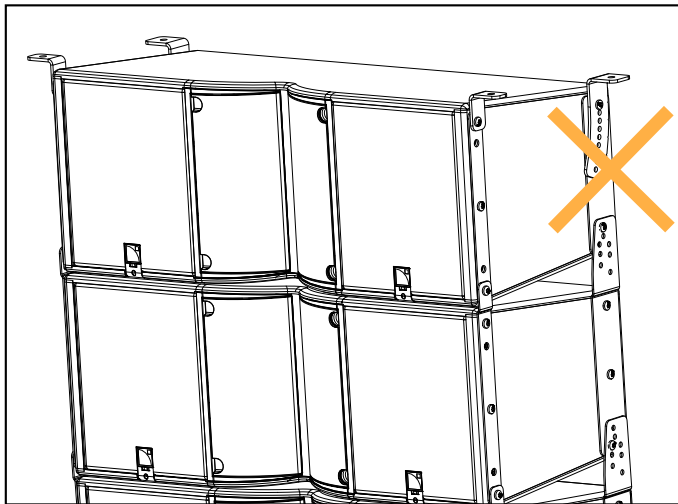

K3i-CEILINGBRACKET

K3i-CEILINGBRACKET is a set of four fastening brackets with site angle adjustment to mount K3i under the ceiling.

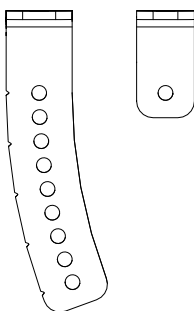

K3i-ENLINK is required on the top enclosure.

The angles can be set at the rear for downwards site angles or the front for upwards site angles.

Using K3i-CEILINGBRACKET at the rear, the site angle can be set between -5° and 15° in 2.5° steps.

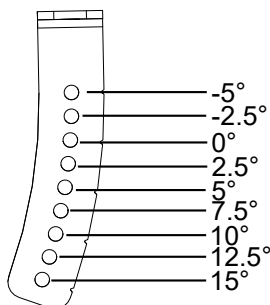
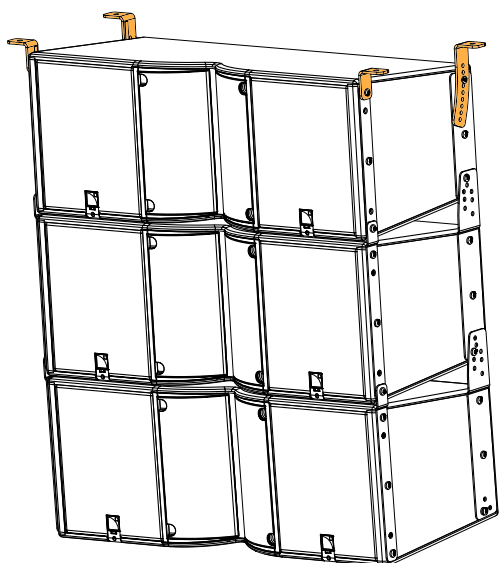

Using K3i-CEILINGBRACKET at the front, the site angle can be set between -5° and -25° in 2.5° steps.

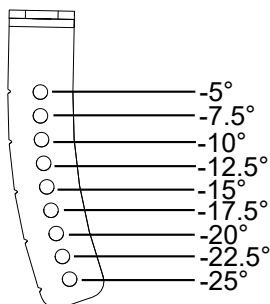
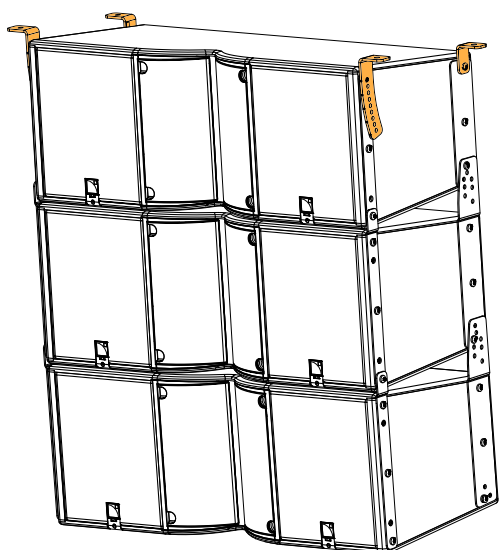

When used at the front, it is not possible to use K3i-SCREEN.

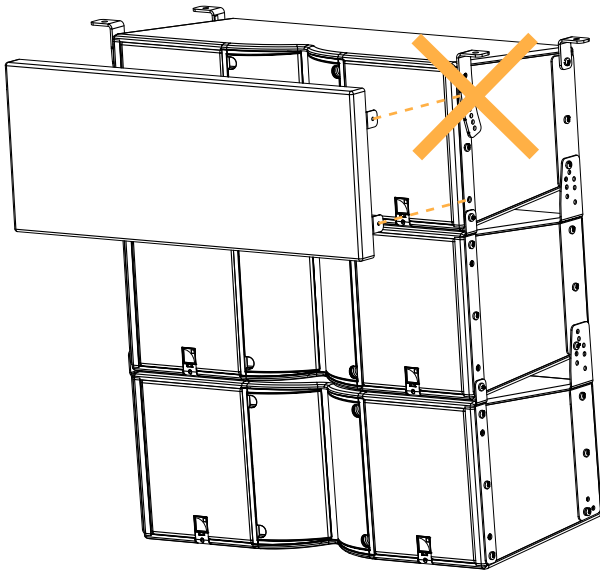

! Fasteners for ceiling-mounting.

Select screw length and anchors applicable to the ceiling properties.

K3i-CEILINGBRACKET is not allowed for a stack of K3i. Always secure a stacked array to the ground using K3i-TILTBRACKET to ensure stability of the array.

K3i-SCREEN

The K3i system features an acoustically transparent front screen suitable for flown or stacked arrays.

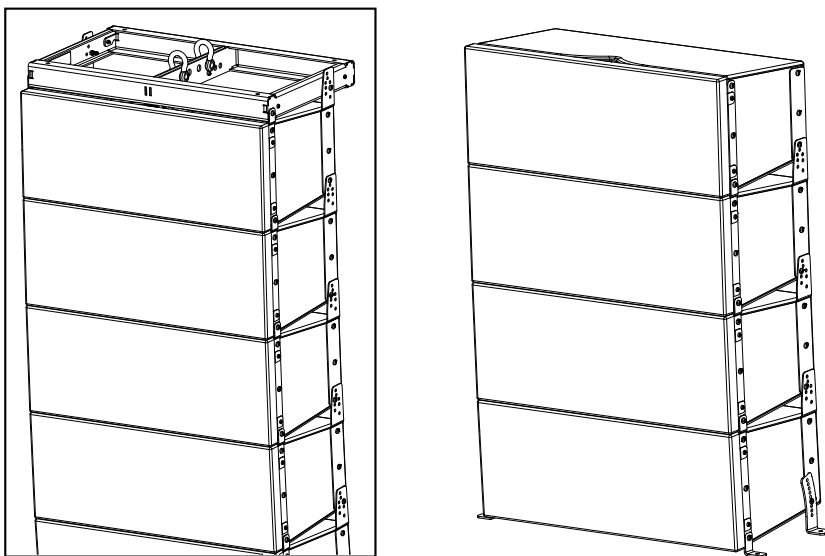

The screen is secured on top of the rigging plates with four M6x25 rigging screws. The placeholder screws can be removed through the rigging plates.

Mechanical safety

Flown configurations

The K3i rigging system complies with 2006/42/EC: Machinery Directive. It has been designed following the guidelines of BGV-C1.

2006/42/EC: Machinery Directive specifies a safety factor of 4 against the rupture. The flown deployments described in this manual achieve a safety factor of **4 or more**.

Refer to Soundvision for the safety factor of a specific deployment.

The **safe limit** gives the maximum number of elements for which the safety factor is compliant with the 2006/42/EC: Machinery Directive, within the use defined in this manual and regardless of the other deployment parameters (site angles, inter-element angles, etc.).

The **maximum limit** gives the maximum number of elements for which the safety factor can be compliant with the 2006/42/EC: Machinery Directive, when the other deployment parameters provide the best mechanical conditions.

For mixed arrays refer to your Soundvision model.

K3i

configuration	rigging accessory	safe limit	maximum limit
flown	K3i-BUMP + K3i-BAR (optional) + rigging plates	12	24
flown and pullback	K3i-BUMP + K3i-BAR + K3i-RIGBAR + rigging plates	12	16
	K3i-RIGBAR x 2 + rigging plates		
ceiling-mounted	K3i-CEILINGBRACKET + rigging plates	3	

K3i + Kara Ili

configuration	rigging accessory	maximum limit
flown with a downfill	K3i-BUMP + KARAlli-DOWNK3i + rigging plates	12 K3i + 6 Kara Ili
flown with a downfill and pullback	K3i-BUMP + K3i-BAR + KARAlli-DOWNK3i + KARAlli-RIGBAR + rigging plates	10 K3i + 6 Kara Ili

Other configurations

For other configurations, respect the recommended maximum limit for optimal stability.

K3i

configuration	rigging accessory	safe limit	maximum limit
stacked	K3i-TILTBRACKET + rigging plates	4 K3i	6 K3i

Assessing mechanical safety

-  **Mechanical safety of the rigging system**
Before any installation, always model the system in Soundvision and check the **Mechanical Data** section for any stress warning or stability warning.

In order to assess the actual safety of any array configuration before implementation, refer to the following warnings:

-  **Rated working load limit (WLL) is not enough**
The rated WLL is an indication of the element resistance to tensile stress. For complex mechanical systems such as loudspeaker arrays, WLLs cannot be used per se to determine the maximum number of enclosures within an array or to assess the safety of a specific array configuration.

Maximum pullback angle

If a pullback accessory is available, the pullback angle must not exceed a 90° negative site angle.

Mechanical modeling with Soundvision

The working load applied to each linking point, along with the corresponding safety factor, will depend on numerous variables linked to the composition of the array (type and number of enclosures, splay angles) and the implementation of the flying or stacking structure (number and location of flying points, site angle). This cannot be determined without the complex mechanical modeling and calculation offered by Soundvision.

Assessing the safety with Soundvision

The overall safety factor of a specific mechanical configuration always corresponds to the lowest safety factor among all the linking points. Always model the system configuration with the Soundvision software and check the **Mechanical Data** section to identify the weakest link and its corresponding working load. By default, a stress warning will appear when the mechanical safety goes beyond the recommended safety level.

Safety of ground-stacked arrays in Soundvision

For ground-stacked arrays, a distinct stability warning is implemented in Soundvision. It indicates a tipping hazard when the array is not secured to the ground, stage or platform. It is the user's responsibility to secure the array and to ignore the warning.

Additional safety for flown arrays

When flying an array, use available holes to implement a secondary safety.

Considerations must be given to unusual conditions

Soundvision calculations are based on usual environmental conditions. A higher safety factor is recommended with factors such as extreme high or low temperatures, strong wind, prolonged exposition to salt water, etc. Always consult a rigging specialist to adopt safety practices adapted to such a situation.

Loudspeaker configurations

Line source

Deployed as a line source, the system operates over the nominal bandwidth of the K3i enclosure, with an adjustable horizontal directivity.

The [K3 70], [K3 90], and [K3 110] presets allow for a reference frequency response in long throw applications. Each preset is dedicated to a horizontal directivity setting.

K3i is driven by the LA4X / LA8 / LA12X amplified controllers.

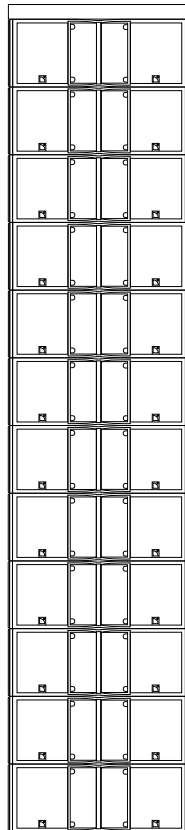

Enclosure	K3i
Preset	[K3 70] [K3 90] [K3 110]
Frequency range (-10 dB)	42 Hz - 20 kHz

Line source with low-frequency element

A K3i line source can be deployed with additional subwoofer enclosures to extend the bandwidth in the low-end or increase sub-low resources.

The [K3 70], [K3 90], and [K3 110] presets allow for a reference frequency response in long throw applications. Each preset is dedicated to a horizontal directivity setting.

The [xxxx_60] presets provides the subwoofers with an upper frequency limit at 60 Hz in separated or coupled configuration for an optimal frequency coupling with the K3i line source.

Amplified controllers compatibility

	LA2Xi	LA4X	LA8	LA12X
K3i	—	✓	✓	✓
KS28	—	—	—	✓
KS21i	✓	✓	✓	✓



Reduced maximum SPL or drive capacity with LA2Xi: refer to the **LA2Xi owner's manual**.

K3i line source with KS28 or KS21i

2 K3i : 1 KS28 / 3 K3i : 2 KS21i*

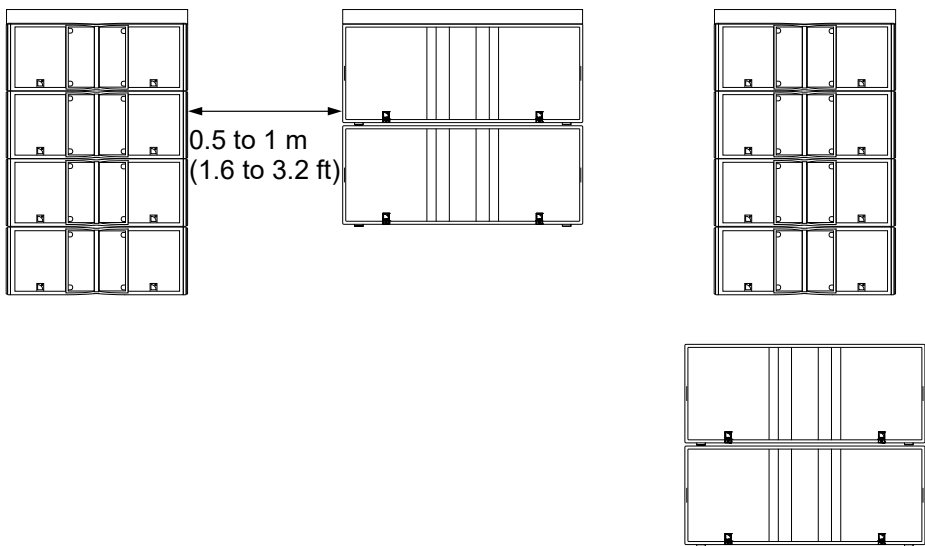

Enclosure	K3i	KS28 or KS21i
Preset	[K3 70] [K3 90] [K3 110]	[xxxx_60]
Frequency range (-10 dB)	25 Hz - 20 kHz (KS28) 29 Hz - 20 kHz (KS21i)	



Grouping subwoofers

Place the subwoofer enclosures side by side. If not possible, the maximum distance between two adjacent acoustic centers must be 2.8 m (9.2 ft) or 1.7 m (5.6 ft) if the upper frequency limit of the subwoofer system is at 60 Hz or 100 Hz, respectively.

* KS21i/KS28 cannot be mechanically coupled with a K3i line source in an array. The KS21i/KS28 and K3i arrays must be flown or stacked independently. Refer to the **KS21i/KS28 owner's manuals** for more information on how to set up a KS21i/KS28 array.

! Use [xxxx_xx_C] or [xxxx_xx_Cx] on a reversed subwoofer in a cardioid configuration

The cardioid configuration consists in reversing 1 element in an array of 4 subwoofers.

Refer to the subwoofer owner's manual and to the **Cardioid configurations** technical bulletin.

! Delay values

Do not forget to add the pre-alignment and geometric delays depending on the configuration.

Pre-alignment delays

K3 + KS28

presets	pre-alignment delay values and polarity settings			
[K3] + [KS28_60]	K3 = 0.5 ms	<input type="checkbox"/>	KS28 = 0 ms	<input type="checkbox"/>
[K3] + [KS28_60_C]	K3 = 6 ms	<input type="checkbox"/>	KS28 = 0 ms	<input type="checkbox"/>
[K3] + [KS28_60_Cx]	K3 = 4 ms	<input type="checkbox"/>	KS28 = 0 ms	<input type="checkbox"/>

K3 + KS21

presets	pre-alignment delay values and polarity settings			
[K3] + [KS21_60]	K3 = 0 ms	<input type="checkbox"/>	KS21 = 0 ms	<input type="checkbox"/>
[K3] + [KS21_60_C]	K3 = 5.5 ms	<input type="checkbox"/>	KS21 = 0 ms	<input type="checkbox"/>
[K3] + [KS21_60_Cx]	K3 = 5 ms	<input type="checkbox"/>	KS21 = 0 ms	<input type="checkbox"/>

Additional downfill element

All K3i system configurations can be combined with an additional Kara Ili line source downfill system. This allows an extension of the vertical coverage to the closer audiences.

Kara Ili

The Kara Ili enclosures are driven by the LA4X / LA8 / LA12X amplified controllers.

The Kara Ili enclosures are also driven by the LA2Xi amplified controller.



Reduced maximum SPL or drive capacity with LA2Xi: refer to the **LA2Xi owner's manual**.



The [KARAIIDOWNK3] preset is optimized for a **110°** fins setting on Kara Ili.

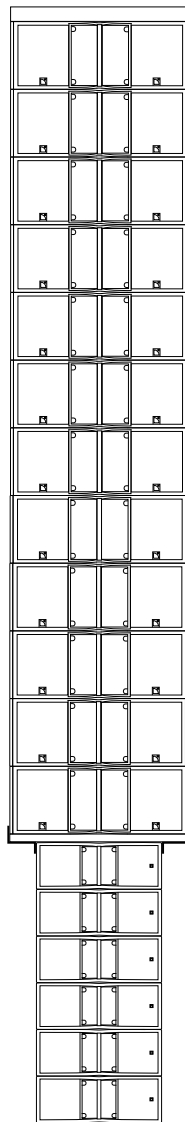

Enclosure	K3i	Kara Ili
Preset	[K3 70] [K3 90] [K3 110]	[KARAIIDOWNK3]
Frequency range (-10 dB)	42 Hz - 20 kHz	



Do not add any delay between the K3i and Kara Ili elements of a mixed line source.

**Using the Kara Ili system**

Refer to the **Kara Ili owner's manual** for the operating modes of Kara Ili as a main system.

Inspection and preventive maintenance

How to do preventive maintenance

Inspect the system after any corrective maintenance operation.

Perform preventive maintenance at least once a year.

Rigging and hardware

Perform the [Rigging part inspection](#) (p.37) on each rigging part.

Use the [Mechanical system overview](#) (p.38) to identify critical parts of the system.

If any parts are damaged, contact your L-Acoustics representative for further instructions.

Acoustics

Perform the [Enclosure check](#) (p.42).

Perform the [Listening test](#) (p.44) to detect any degradation in sound quality.

If necessary, refer to the [Corrective maintenance](#) (p.77) section for speaker repair kits and maintenance instructions.

Rigging part inspection

About this task

The term "rigging part" comprises:

- lifting accessories such as clamps and shackles
- rigging accessories such as rigging frames, rigging interfaces, and brackets
- fasteners used for assembling two products together such as ball-locking pins, rigging axes, and safety pins
- rigging plates mounted on enclosures and their rigging screws
- screens mounted on enclosures

This inspection procedure covers only L-Acoustics products. To inspect other products that are part of the lifting chain, refer to the manufacturer's instructions.

Prerequisite

Perform the inspection in a well-lit environment.

Procedure

1. Check that the rigging part is present.
2. Check for:
 - corrosion
 - wear and cracks
 - bends and dents
 - holes
 - missing safety cues
 - missing identification labels
 - missing or loose fasteners



Replacing screws

If a screw is loose, remove and replace it.

Always use the new screws provided in the repair kit.

If no new screw is available, add blue threadlocker before reusing the screw.

Do not apply more than the indicated torque.

3. Check the geometry of the part to identify critical deformations.

What to do next

If a problem is detected, perform the authorized maintenance operations or contact your L-Acoustics representative.

Mechanical system overview

Critical parts of the lifting chains are highlighted.



The  indicates a visual inspection.



Perform the [Rigging part inspection](#) (p.37) on critical parts.



Replacing screws

If a screw is loose, remove and replace it.

Always use the new screws provided in the repair kit.

If no new screw is available, add blue threadlocker before reusing the screw.

Do not apply more than the indicated torque.

K3i and Kara Ili with K3i-BAR and K3i-BUMP

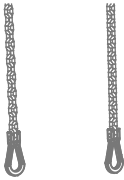

shackle axis end is flush with the shackle

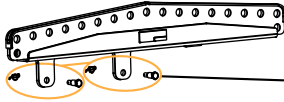
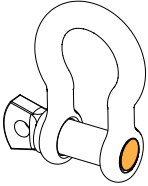
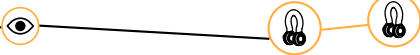

rigging axis are secured with nuts and safety pins

nuts are secured and tightened

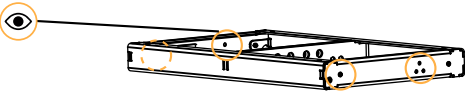

Rigging part inspection (p.37)

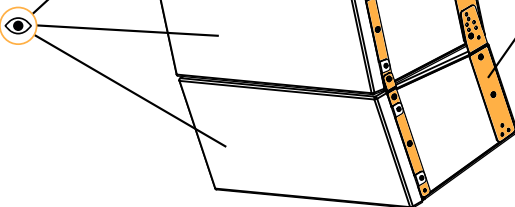

rigging screws are tightened
Rigging part inspection (p.37)

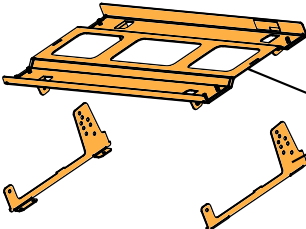

rigging elements are not bent
rigging screws are tightened
Rigging part inspection (p.37)

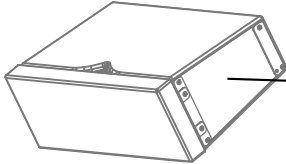

refer to the Kara Ili Owner's Manual

K3i with K3i-RIGBAR and pullback

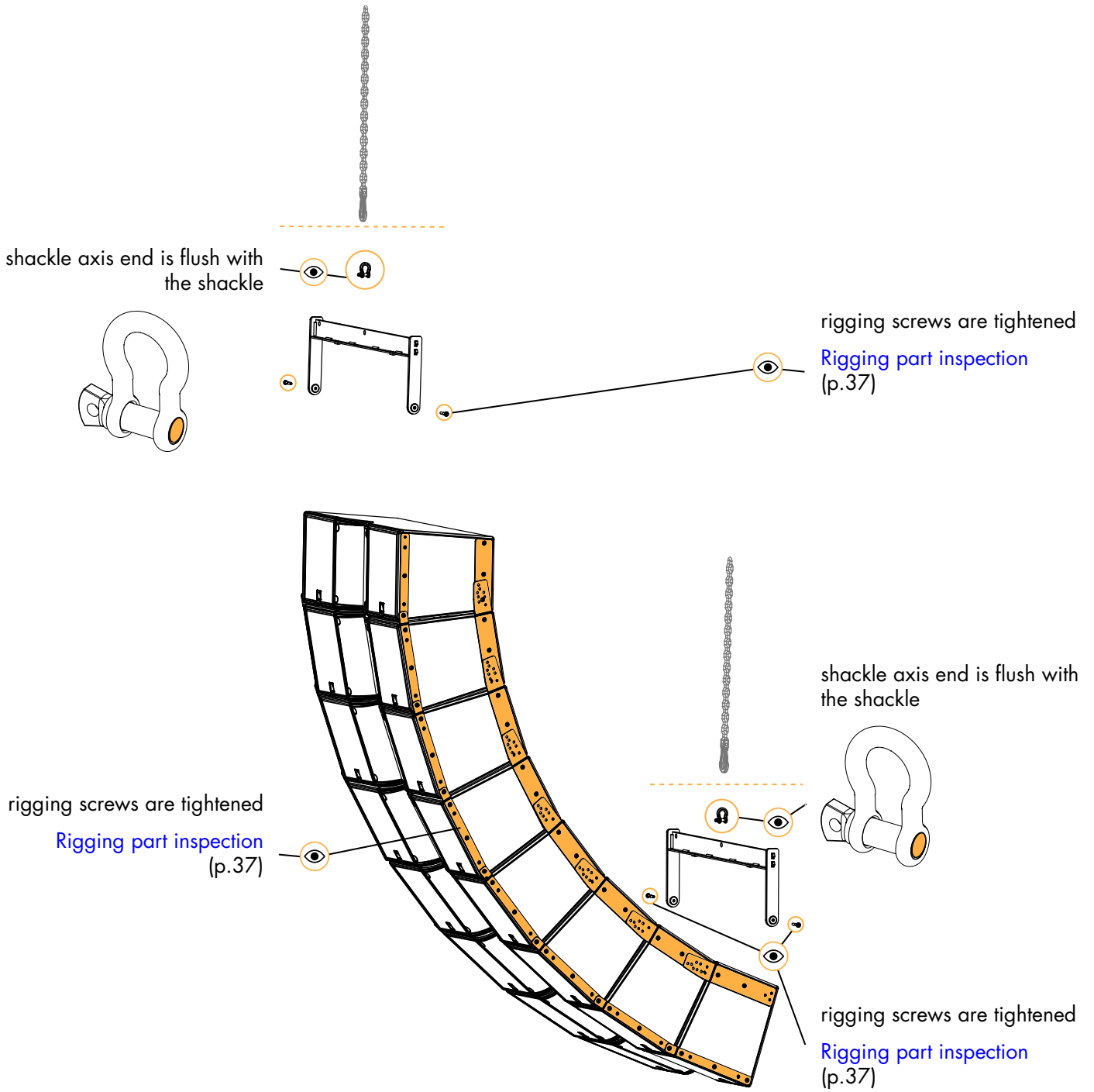

K3i ceiling-mounted with K3i-CEILINGBRACKET

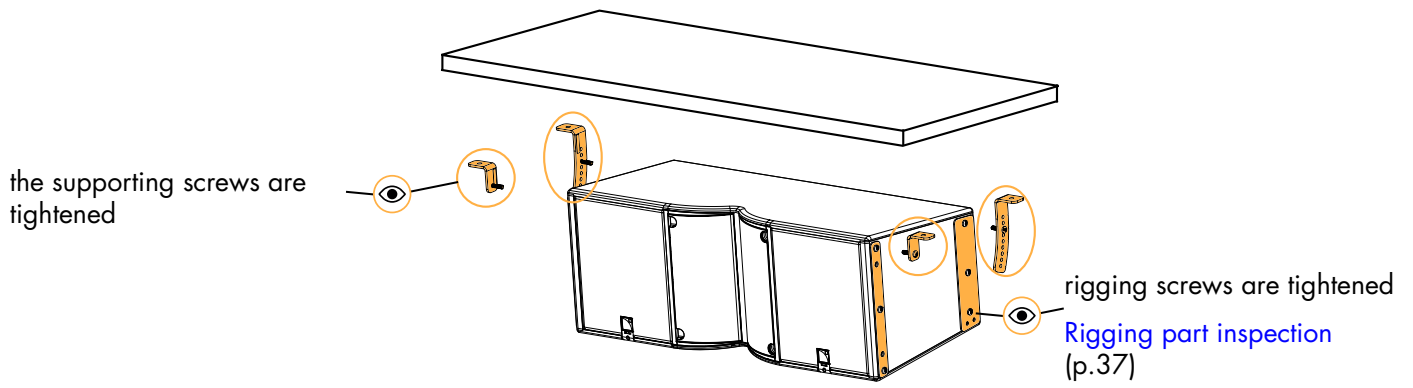

K3i stacked on K3i-TILTBRACKET

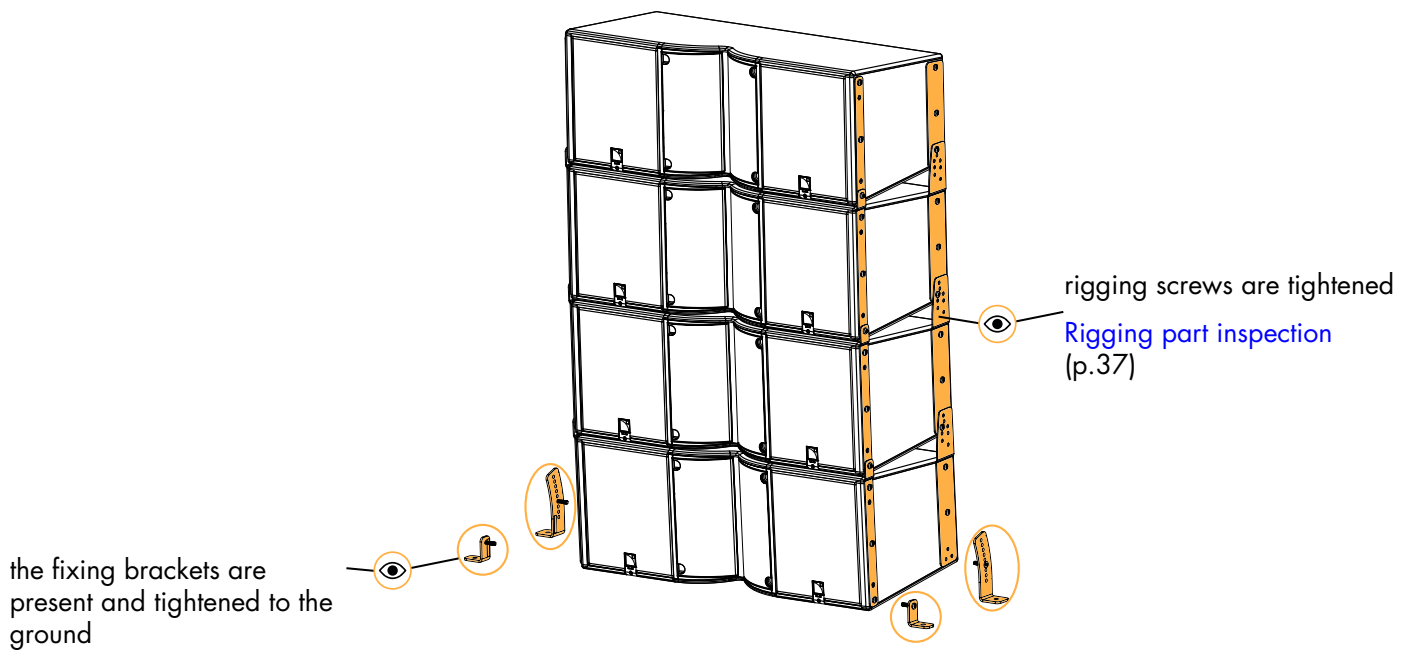

Acoustical check

Enclosure check

-  **This feature is available on:**
 LA4X
 LA12X

ENCLOSURE CHECK measures impedance at the reference frequencies for the connected loudspeaker family. The measured impedance is compared to the expected range allowing for fast detection of loudspeakers presenting circuit continuity issues.

 The results can be used for preliminary diagnosis but cannot replace a comprehensive quality control.

Prerequisite

-  **ENCLOSURE CHECK measurements can only be reliable if the following requirements are met:**

Environment and temperature:

- Ambient temperature must be comprised between 0 °C / 32 °F and 40 °C / 104 °F. Ideal temperature is 20 °C / 68 °F.
- Enclosures must be at room temperature. If warm from a recent high level use or recently moved from a cold environment, let the loudspeakers reach room temperature before starting.

Enclosures:

- Enclosures must be included in the embedded factory preset library.
- Enclosures must be in nominal operating conditions:
 - Remove covers or dollies obstructing the loudspeakers or the vents.
 - Check for obvious physical damage or air leak: visually inspect the grill, gasket, cabinet, and connector plate for loose, missing or damaged parts.

Connection:

- Use only 10 m / 30 ft 4 mm² / AWG 11 speaker cables.
- Do not connect enclosures in parallel.

Amplified controllers:

- LA4X must run at least firmware version 1.1.0.
- LA4X load sensors must be calibrated. Refer to the **Load Sensor Calibration Tool** technical bulletin for more information.
- LA4X must warm up for at least 10 minutes after power up. Do not power off, reboot or switch to standby mode to avoid resetting the countdown.
- Load a preset corresponding to the connected loudspeaker's family. Presets from the user memories may be used on condition they are made of presets supported in the embedded factory preset library.

Procedure

1. Power up the amplified controller. Let LA4X warm up for at least 10 minutes.
2. Connect the loudspeaker enclosures to the amplified controller.
3. Load a preset from or built from the embedded library corresponding to the connected loudspeaker family.
4. On the amplified controller, use the encoder wheel to select **MONITORING & INFO**. Press the OK key or the encoder wheel to validate.
5. Use the encoder wheel to select **ENCLOSURE CHECK**.



Beware of sound levels.

Although the sound pressure levels generated for the ENCLOSURE CHECK are moderate, do not stay within close proximity of the loudspeakers and consider wearing ear protection.

6. Press the OK key or the encoder wheel to launch the ENCLOSURE CHECK.

The amplified controller generates short sinusoidal signals simultaneously for each connected output.

The amplified controller displays the results for each output.

7. Depending on the displayed results, follow the instructions in the table.

result	interpretation	instructions
OK	measured impedance is within expected range	enclosure is in working order electrically
?	unsupported preset family	only supported enclosures should be tested
NC	Not Connected	if cables are connected: a. inspect the cables and connections b. go to step 8 (p.43)
NOK	measured impedance is not within expected range	a. check that all the prerequisites are met, in particular that the loaded preset corresponds to the connected speaker's family b. inspect the cables and connections c. go to step 8 (p.43)
UNDEF	measured impedance is undefined	

8. Under NC, NOK and UNDEF results, press and hold the corresponding OUT key.

The amplified controller displays:

- the tested frequencies,
- information on the measured impedance:
 - OPEN for open circuit (found in NC results),
 - SHORT for short circuit (found in NOK results), or
 - a percentage of variation from the expected range (found in NOK and UNDEF results)
- the number of operational transducers out of the total



Low variations from the expected range are acceptable: displayed percentage can be different from 0 and all transducers considered operational.

Listening test

enclosure	preset	usable bandwidth
K3i	[K3 70]	42 Hz - 20 kHz

Procedure

1. Load the preset on an LA4X / LA8 / LA12X amplified controller.
2. Connect a sinus generator to the amplified controller.



Risk of hearing damage

Set a low sound level to start and use ear protection to adjust before testing.

3. Scan the bandwidth focusing on the usable range.
The sound should remain pure and free of unwanted noise.
4. Focus on the 35 Hz frequency.
The sound should remain pure and free of unwanted noise.

Troubleshooting for LF speakers

One or more LF speaker produces distorted, buzzing, rubbing, clicking, muffled or weak sound.

Possible causes

- The screws are not tightened with the appropriate torque.
- There is an air leak in the gasket.
- There is dust on the cone.
- The cone is damaged.
- The surround is torn or delaminated.
- The voice coil or the spider is damaged.

Procedure

1. Perform the speaker disassembly procedure.
2. Visually inspect the cables and the connectors.
3. Visually inspect the speaker cone, the voice coil and the spider.
If any damage is visible, replace the speaker.
4. Carefully clean the speaker with a dry cloth.
5. Perform the reassembly procedure.
Replace the speaker gasket and the screws.
Apply the recommended torque.
6. Repeat the listening test.
If the problem persists, replace the speaker.

Troubleshooting for HF drivers

One or more HF driver produces high-frequency harmonic distortions, strange vibrations or weak sound.

Possible causes

- There are foreign particles on the air gap.
- The diaphragm is not centered correctly.
- The screws used for reassembly are too loose.
- The diaphragm is damaged.

Procedure

1. Perform the diaphragm disassembly procedure.
2. Visually inspect the diaphragm and the voice coil.
If any damage is visible, replace the diaphragm.
3. Clean the air gap thoroughly.
Use double-face adhesive tape to remove any particles.
4. Perform the diaphragm reassembly procedure.
Apply the recommended torque.
5. Repeat the listening test.
If the problem persists, replace the driver.

Troubleshooting for installation enclosures

One or more enclosure produces a high-pitched, leaking air sound.

Possible cause

- Placeholder screws are missing.

Procedure

Visually inspect the screws on both sides of the enclosures.
Secure placeholder screws in the empty inserts.

Rigging procedures

General principles

This introduction provides general principles applicable for all configurations.

Screws

- ! Rigging screws**
Only use the rigging screws provided by L-Acoustics.
Do not use the placeholder screws for rigging.

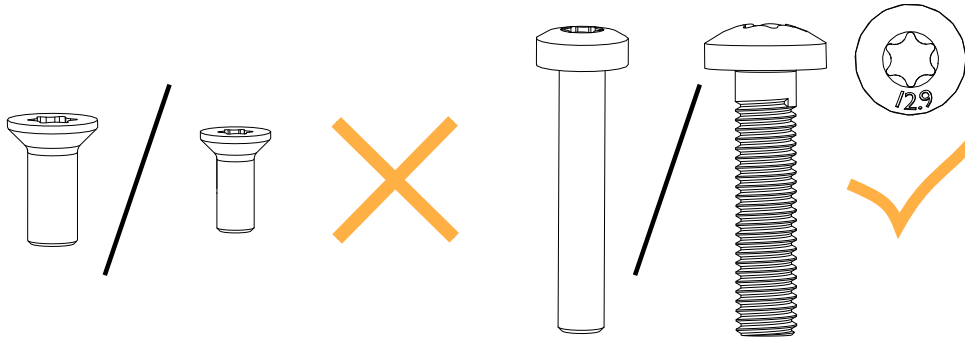

Always remove the relevant placeholder screws before securing the rigging plates.

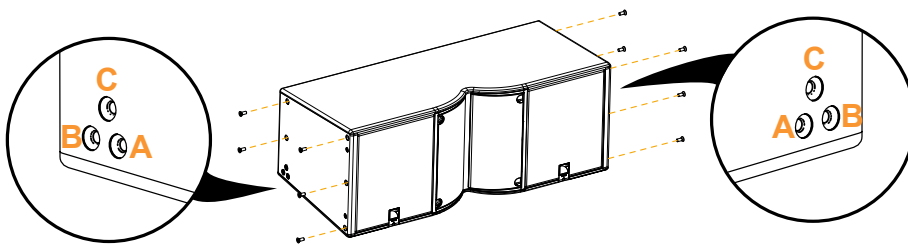

- ! Risk of acoustic leaks**
Do not remove the placeholder screws from the bottom rear inserts (A, B or C) that are not used.

rigging accessory	inter-element angles	used insert
K3i-LINK (connecting from an enclosure below) / KARAlli-DOWNK3i	0.25°, 3°	C
	2°, 5°, 10°	B
	1°, 4°, 7.5°	A
K3i-RIGBAR	—	B
K3i-TILTBRACKET	5°, 2.5°, 0°, -2.5°, -5°, -7.5°, -10°, -12.5°, -15°	A

It is recommended to use the rigging report from Soundvision to prepare the enclosures.

Rigging plate positions

K3i-LINK and K3i-ENDLINK left and right rigging plates are different. Use the visual cues to differentiate them:

- Place the rigging plate side with the label towards the enclosure.
- At the top of K3i-LINK rear: the bottom hole on the linking section is positioned towards the rear of the enclosure.
- At the bottom: the shape of the rigging plate is parallel to the edge of the enclosure and the holes and inserts are aligned.

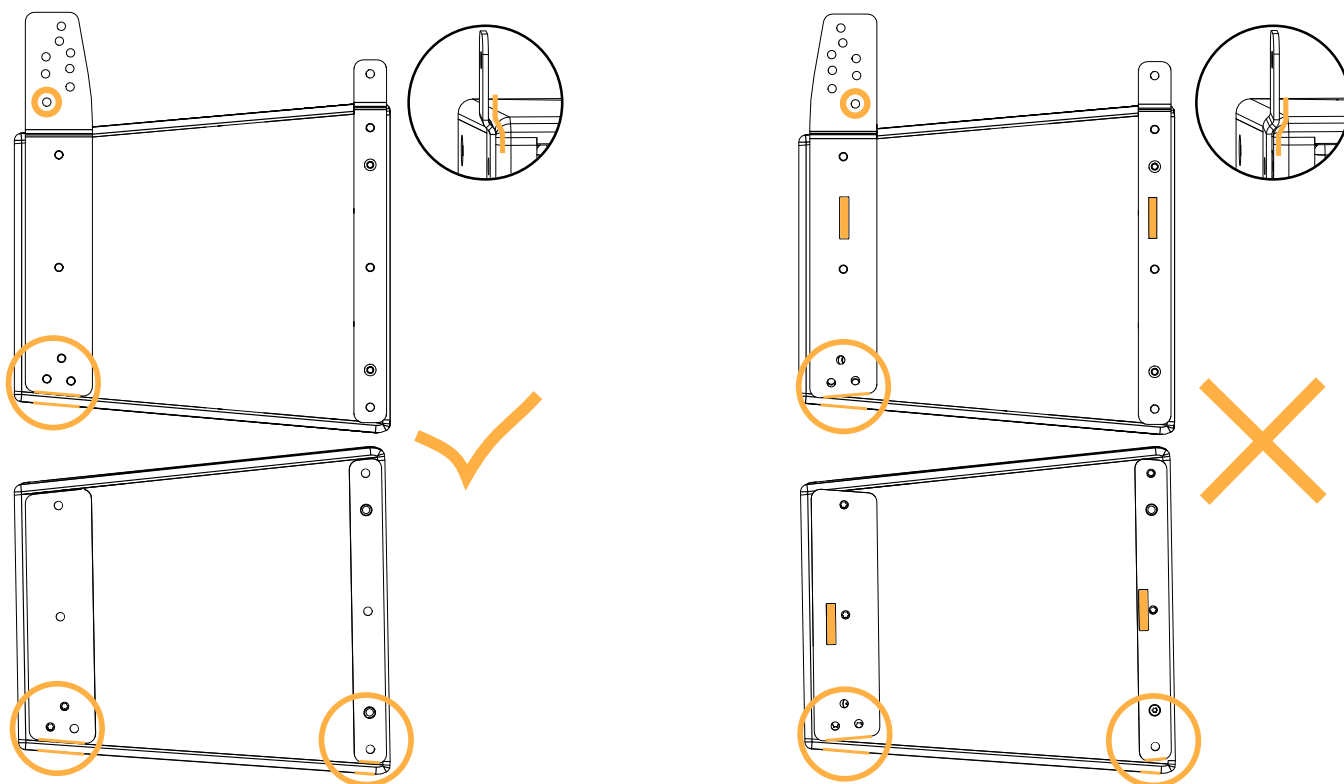

Always secure K3i-LINK with the linking section upwards.

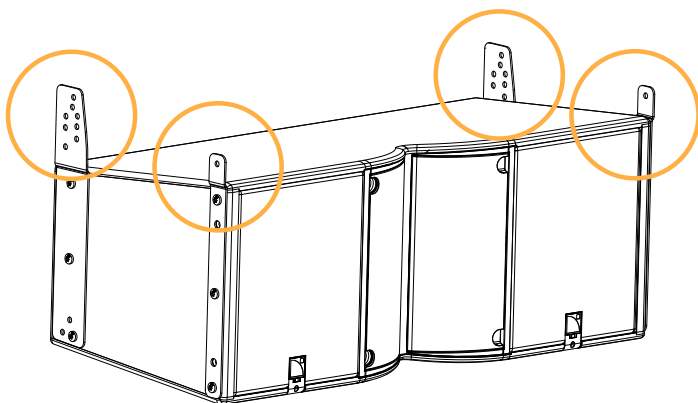

Do not confuse the angle accessories of K3i-TILTBRACKET and K3i-CEILINGBRACKET. The K3i-TILTBRACKET angle accessory is wider and smaller than the K3i-CEILINGBRACKET angle accessory.

K3i-TILTBRACKET

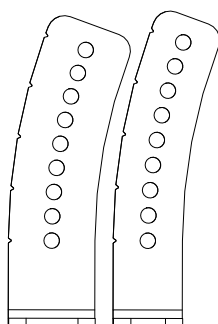

K3i-CEILINGBRACKET

Tightening screws



Driving screws

Do not fully tighten the screws unless otherwise instructed.

Follow the indicated torque when tightening a screw.

When securing a rigging plate to an enclosure, secure the top and middle screws on both sides. Secure the bottom screws only when instructed to.

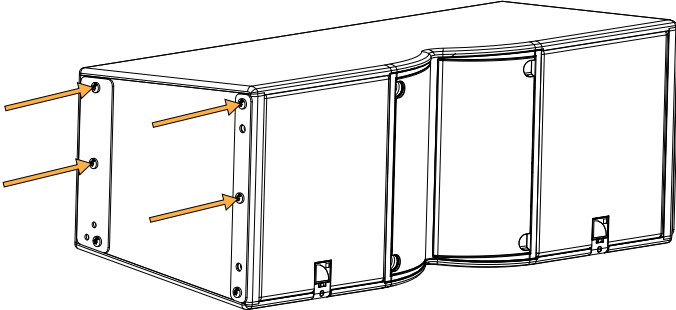

Apply a torque of 7 N.m.

Stacking enclosures



Fastening brackets

Always secure a stacked array to the ground using K3i-TILTBRACKET to ensure the stability of the array.

When stacking two enclosures, the top enclosure must be slightly lifted to align the inserts with the rigging plate holes. Use an accessory like a wedge or a lever to adjust the height of the enclosure. Be careful not to scratch the paint.

Tools

Before rigging this product, make sure all the tools listed are available. References are given for FACOM® products in this table. Other manufacturers can be used.

name	reference	distributor
set of 6-point 1/4" sockets	RL.NANO1 / R.360NANO	FACOM
electric screwdriver with torque selector	-	-

Flying

Flying a K3i array with K3i-BUMP

Type of deployment	flown array
Rigging accessories	K3i-BUMP 2 Ø19 mm shackles WLL 3.25 t (provided) K3i-LINK
Screws and fasteners	4 M8x35 rigging screws and M8 nuts (provided)
Tools	electric screwdriver with torque selector T40 Torx bit 13 mm hex socket
Min number of operators	3

Rigging plates

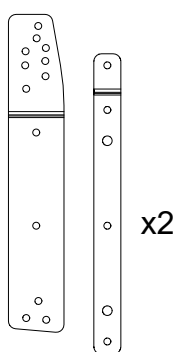

K3i-LINK



Risk of falling objects

Verify that no unattached items remain on the product or assembly.



Additional safety for flown arrays

When flying an array, use available holes to implement a secondary safety.

Procedure

1. Prepare an enclosure:
 - a) Remove the relevant placeholder screws.

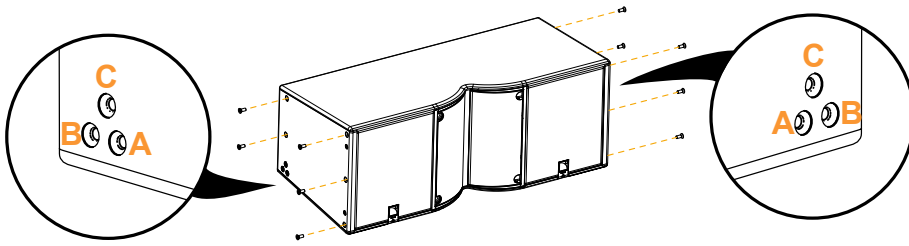

Risk of acoustic leaks

Do not remove the placeholder screws from the bottom rear inserts (A, B or C) that are not used.

rigging accessory	inter-element angles	used insert
K3i-LINK (connecting from an enclosure below) / KARAlli-DOWNK3i	0.25°, 3°	C
	2°, 5°, 10°	B
	1°, 4°, 7.5°	A
K3i-RIGBAR	—	B
K3i-TILTBRACKET	5°, 2.5°, 0°, -2.5°, -5°, -7.5°, -10°, -12.5°, -15°	A

It is recommended to use the rigging report from Soundvision to prepare the enclosures.

- b) Secure K3i-LINK with the top and middle screws on both sides.

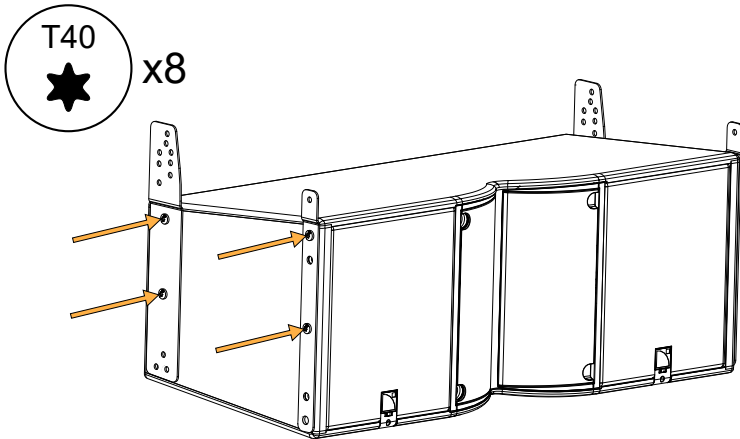

2. Position K3i-BUMP on top of the enclosure.

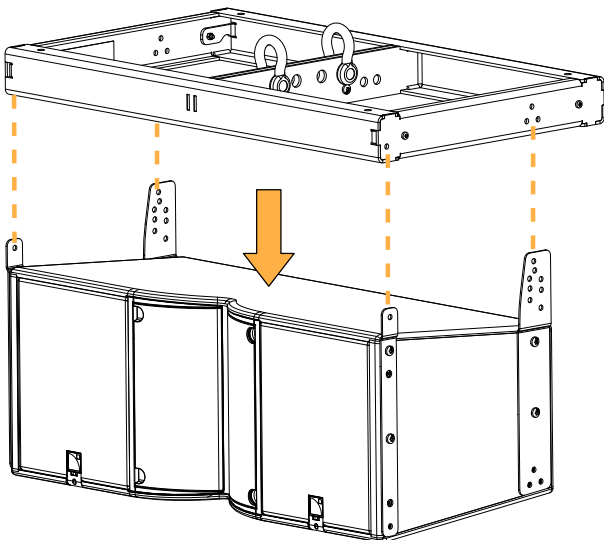

3. Secure K3i-BUMP on top of the enclosure and tighten the screws and nuts.

Select the appropriate holes depending on the selected site angle.

! It is recommended to set a 0° splay angle between the first K3i and K3i-BUMP.
Refer to [K3i-BUMP](#) (p.20).

Apply a torque of 7 N.m.

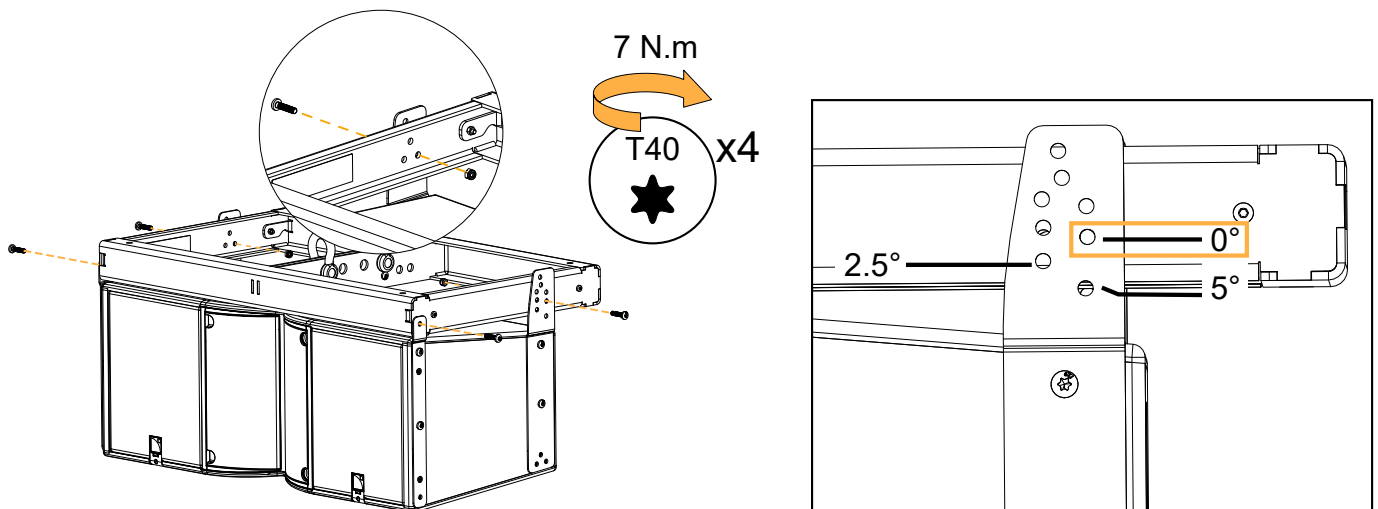

4. Optionally, secure a K3i-BAR on K3i-BUMP to extend the site angle capability, in position A or B.

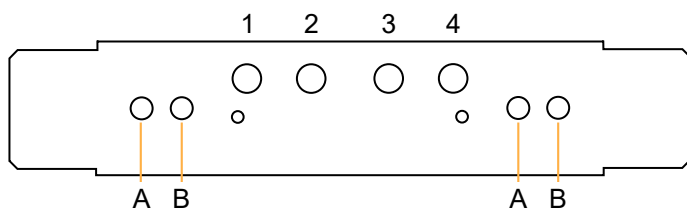

Use the provided rigging axes and nuts, and secure using two 19 mm hex bit. Insert the safety pins.

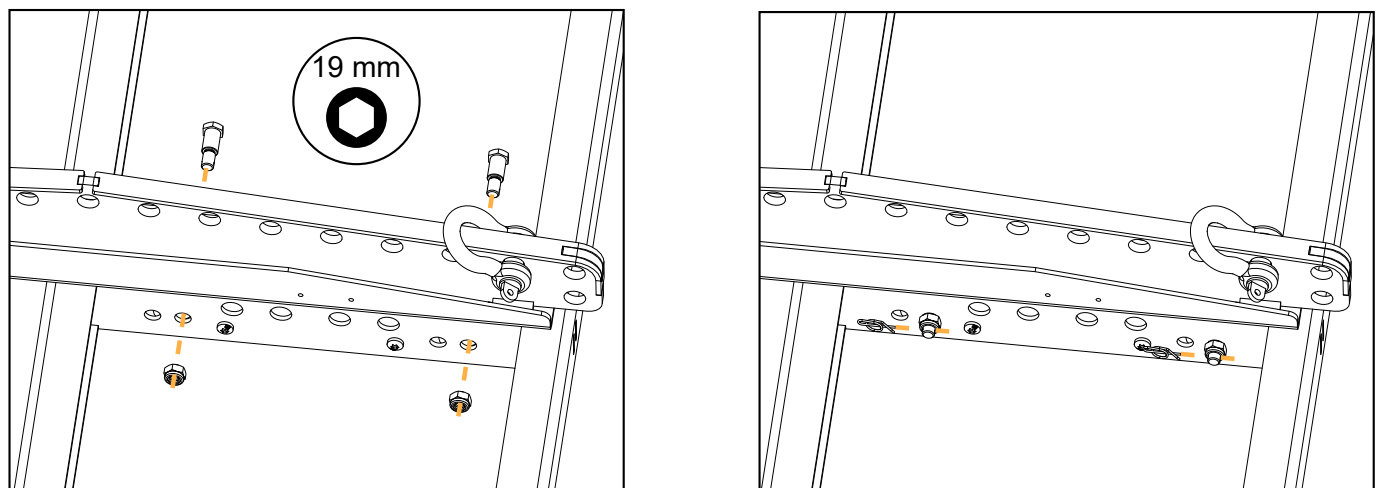

K3i-BAR can be attached as a rear or a front extension. Refer to [K3i-BAR](#) (p.22).

5. Select the pickup points and raise the array.

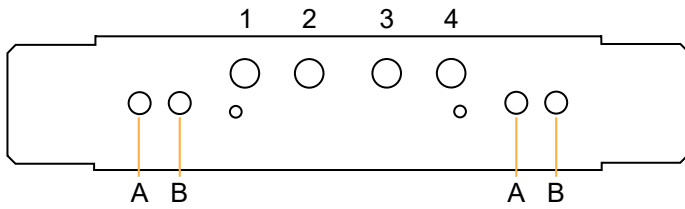

K3i-BUMP pickup points

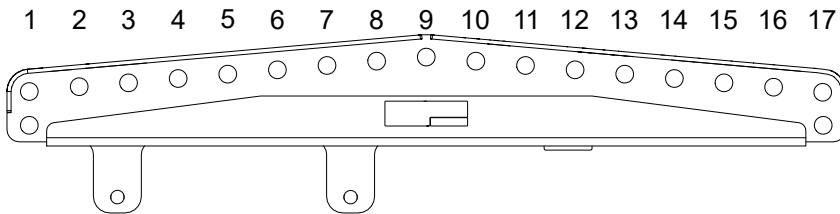

K3i-BAR pickup points

6. Prepare another enclosure. Refer to step 1 (p.50).



This step requires three operators.

Hold the enclosure at the bottom until the rigging plates are secured.

7. Secure the second enclosure under the array:

- a) Lift the second enclosure under the array.

The plates of the lower enclosure must be on top of the plates of the upper enclosure.

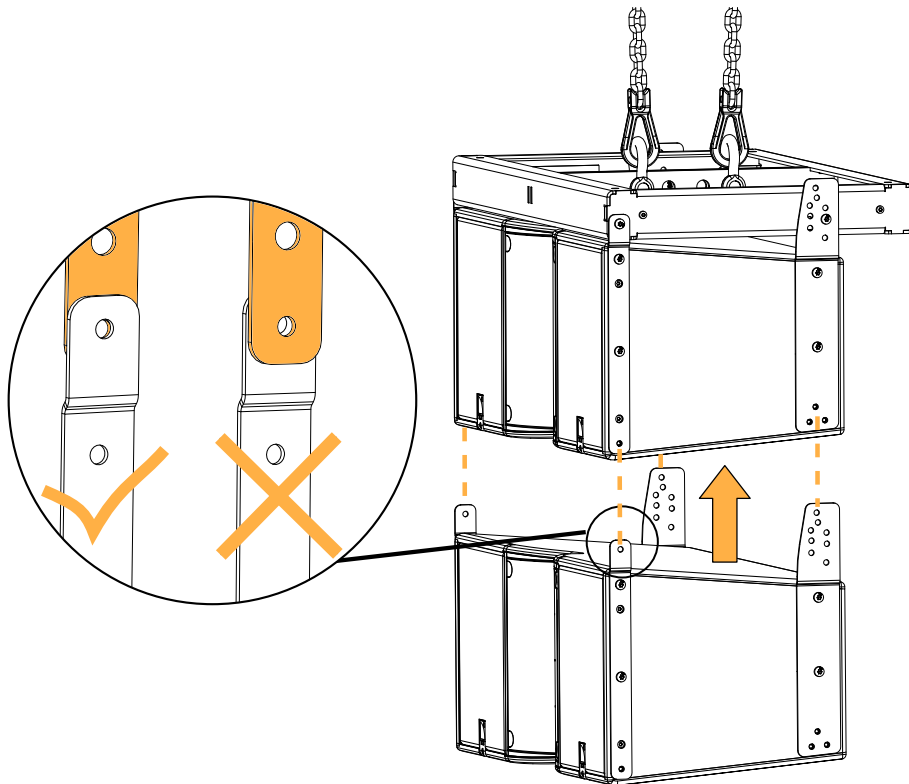

b) Link the enclosures at the front with rigging screws.

Do not fully tighten the screws.

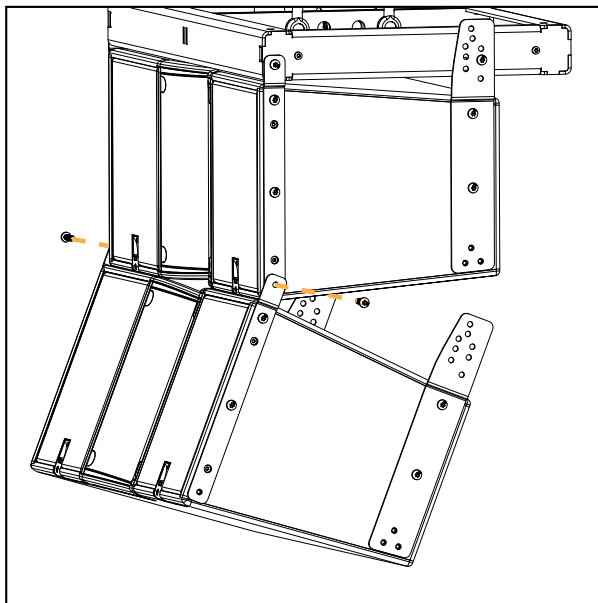

c) Link the enclosures at the rear with the rigging screws.

Select the appropriate holes and inserts depending on the selected angle.

Apply a torque of 7 N.m.

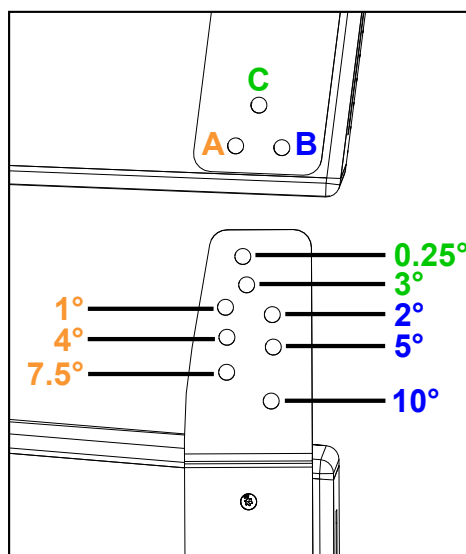
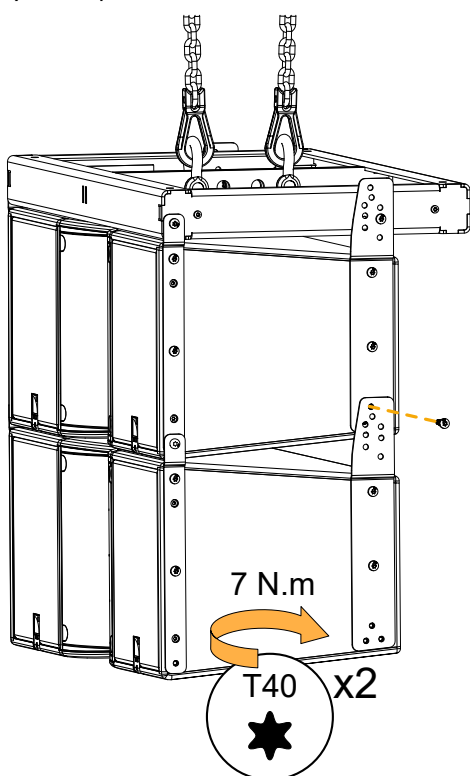

8. Tighten all the screws on the supporting enclosure.

9. Repeat step 6 (p.52) to 8 (p.53) as necessary to complete the array.

10. Unless adding a pullback or a downfill, tighten the screws of the last enclosure of the array on both sides.

Apply a torque of 7 N.m.

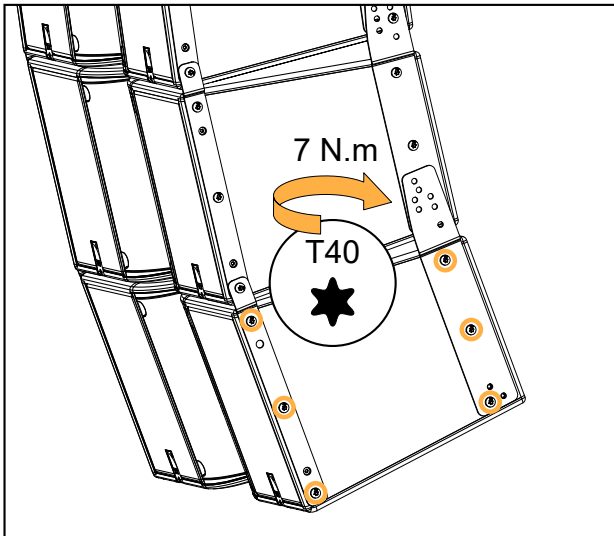

What to do next

To add a pullback, refer to [Adding a pullback with K3i-RIGBAR](#) (p.55).

To add a downfill, refer to [Rigging a Kara Ili downfill array under a K3i array with KARAlli-DOWNK3i](#) (p.58).

To add screens, refer to [Securing a screen](#) (p.71).

Adding a pullback with K3i-RIGBAR

Type of deployment	flown array
Rigging accessories	K3i-RIGBAR
	2 Ø12 mm shackle WLL 1 t (provided)
Screws and fasteners	2 M8x50 rigging screws (provided)
Tools	electric screwdriver with torque selector T40 Torx bit
Min number of operators	2

Rigging plates

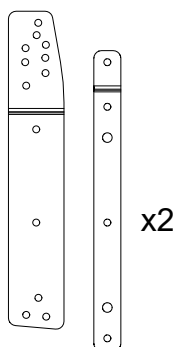

K3i-LINK

⚠ Risk of falling objects
Verify that no unattached items remain on the product or assembly.

⚠ Additional safety for flown arrays
When flying an array, use available holes to implement a secondary safety.

Procedure

1. Prepare an array of K3i. Refer to [Flying a K3i array with K3i-BUMP](#) (p.49).
2. Attach K3i-RIGBAR to a motor using one Ø12 mm shackle WLL 1 t.

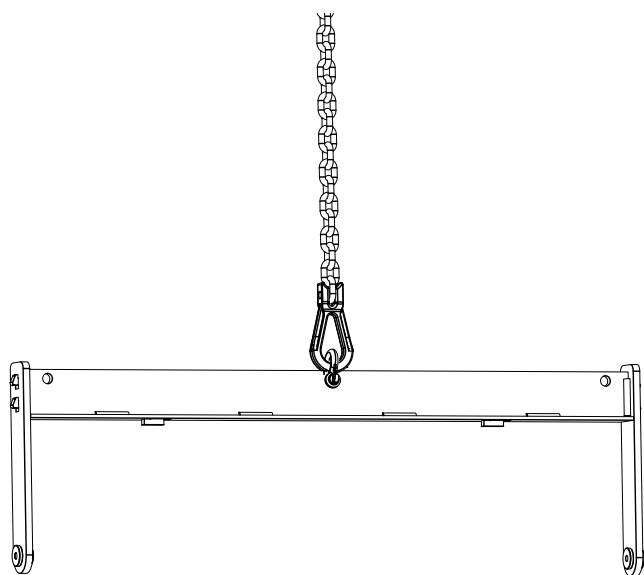

3. Secure K3i-RIGBAR to the bottom enclosure.

Use the enclosure rear hole (insert B).

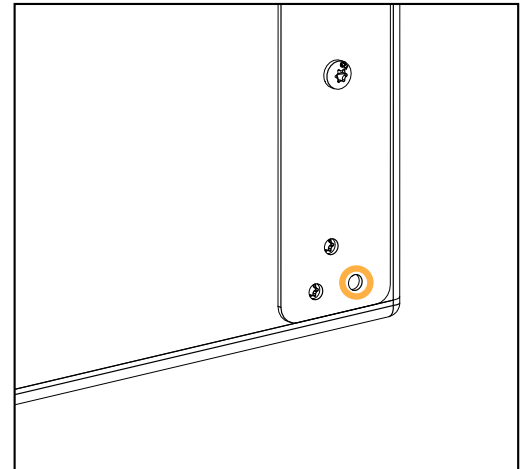
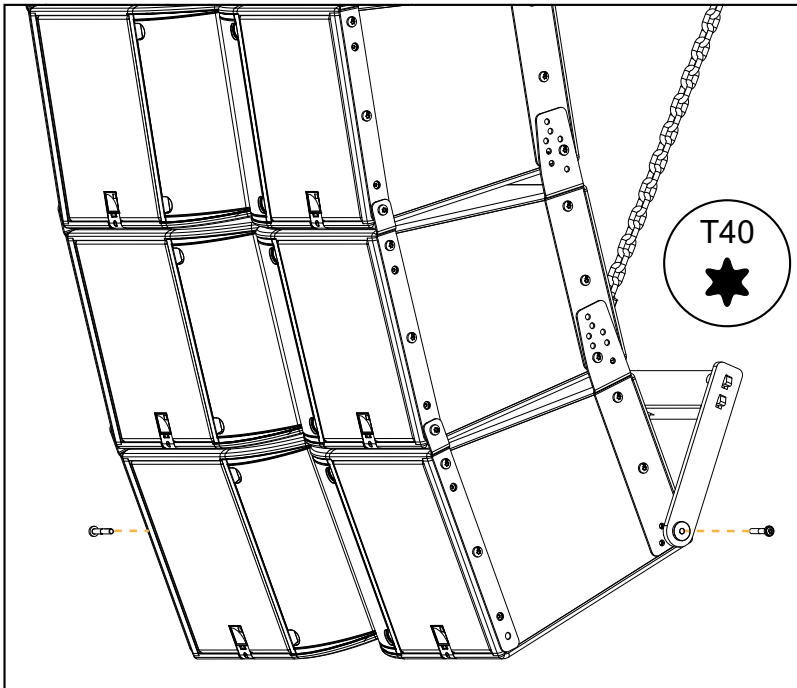

4. Tighten the screws of the bottom enclosure on both sides.

Apply a torque of 7 N.m.

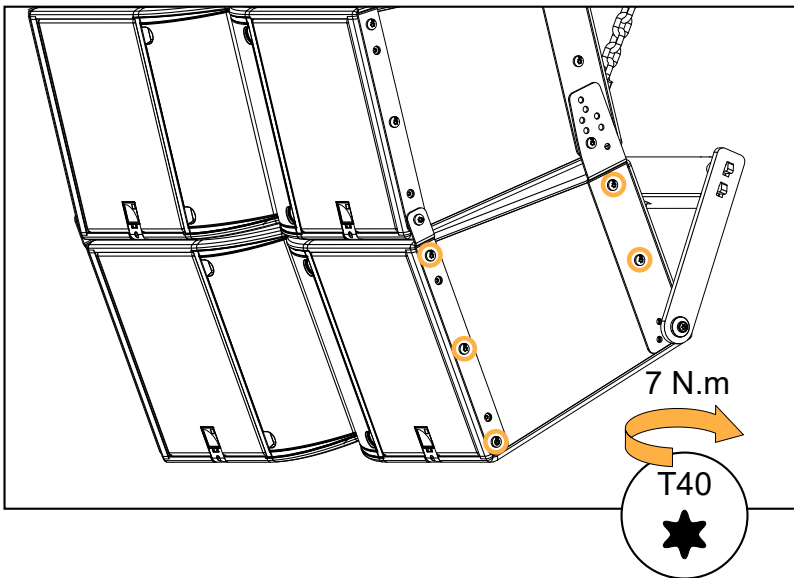

5. Adjust the height of the pick-up points.



The pullback angle must not exceed a 90° negative site angle.
The chains must be as vertical as possible.

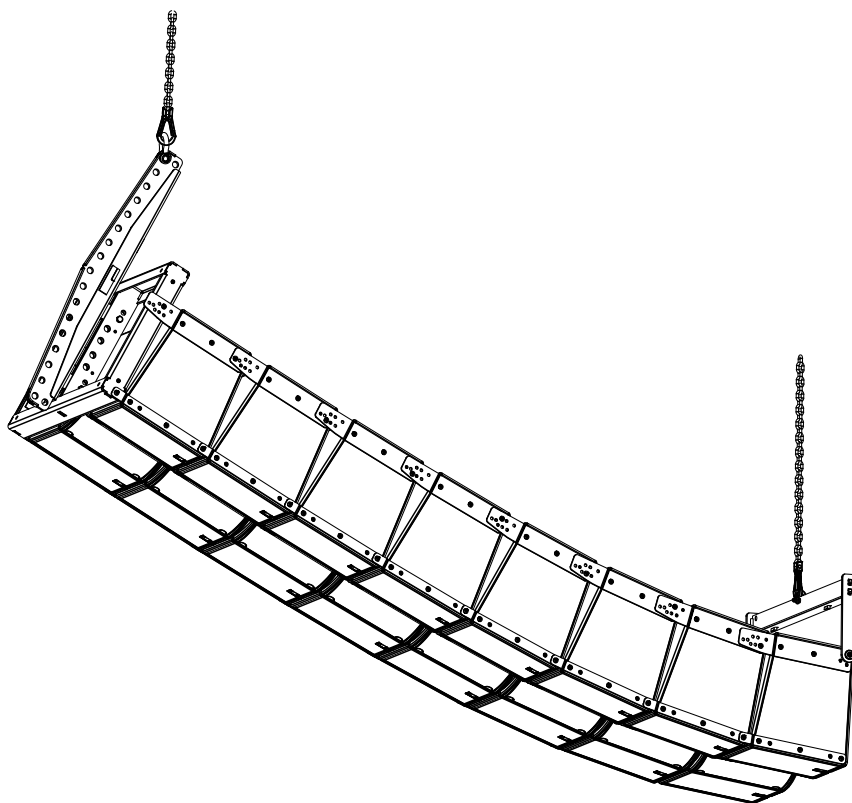

Optionally, the K3i array can be flown using K3i-RIGBAR at the front or at the back of the top enclosure. Follow the procedure from [Flying a K3i array with K3i-BUMP](#) (p.49) using K3i-ENDLINK on the top enclosure.

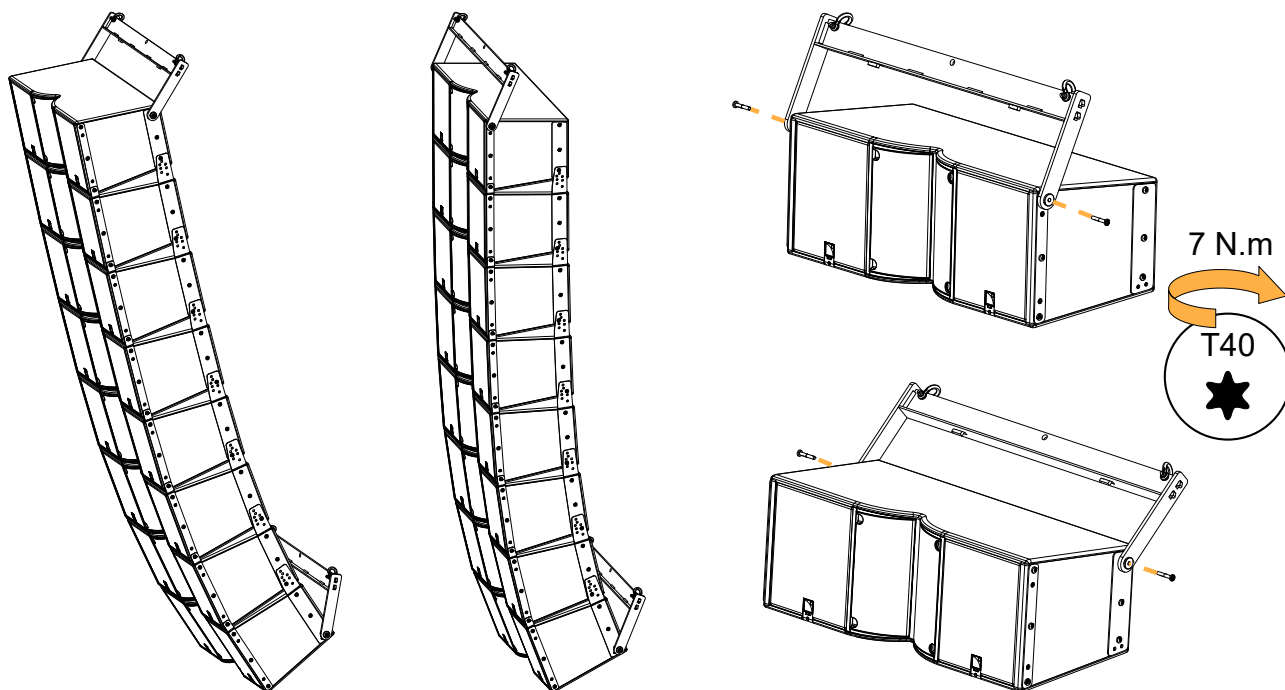

What to do next

To add screens, refer to [Securing a screen](#) (p.71).

Rigging a Kara Ili downfill array under a K3i array with KARAlli-DOWNK3i

Type of deployment	flown array
Rigging accessory	KARAlli-DOWNK3i
Screws and fasteners	4 M8x35 rigging screws (provided) 10 M6x19 rigging screws (provided)
Tools	electric screwdriver with torque selector T40 Torx bit T30 Torx bit
Min number of operators	3

Rigging plates

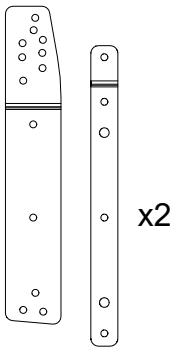

K3i-LINK



Risk of falling objects

Verify that no unattached items remain on the product or assembly.



Additional safety for flown arrays

When flying an array, use available holes to implement a secondary safety.

Procedure

1. Prepare and raise an array of K3i. Refer to [Flying a K3i array with K3i-BUMP](#) (p.49).
2. Prepare a single Kara Ili with KARAlli-ENDLINK. Refer to the **Kara Ili owner's manual**.
3. Assemble the three parts of KARAlli-DOWNK3i with six M6x19 screws.

Do not fully tighten the screws.

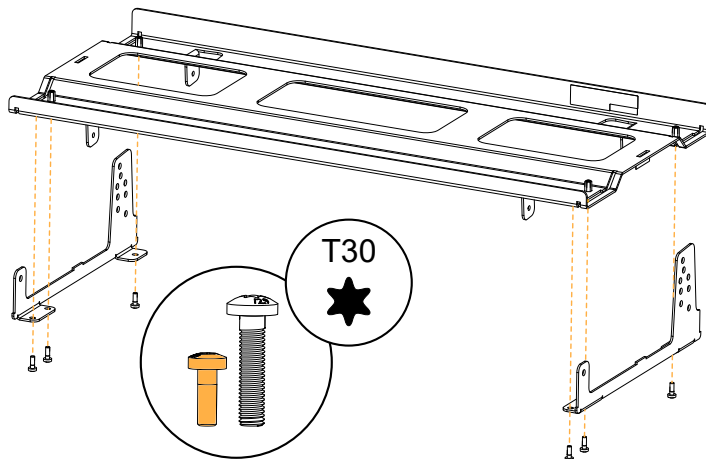

4. Secure KARAlli-DOWNK3i on Kara Ili and tighten the screws.

Use four M6x19 rigging screws. Apply a torque of 5 N.m.

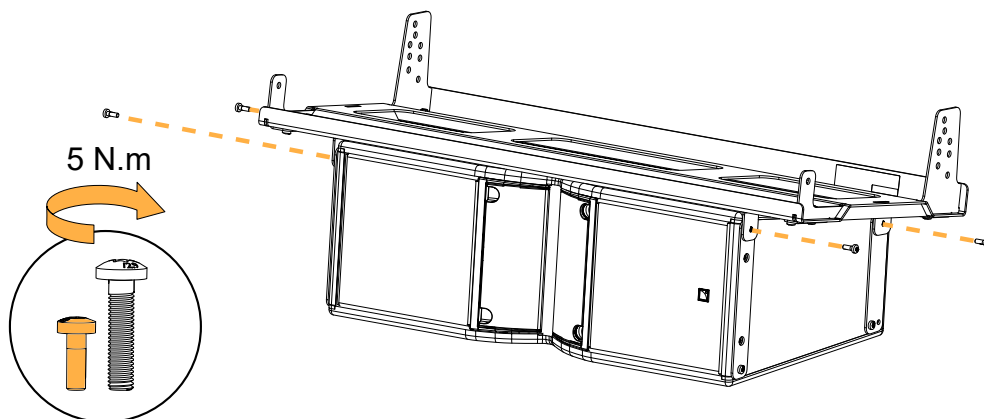

This step requires three operators.

Hold the enclosure at the bottom until the rigging plates are secured.

5. Secure Kara Ili under the array:
a) Lift Kara Ili under the K3i array.

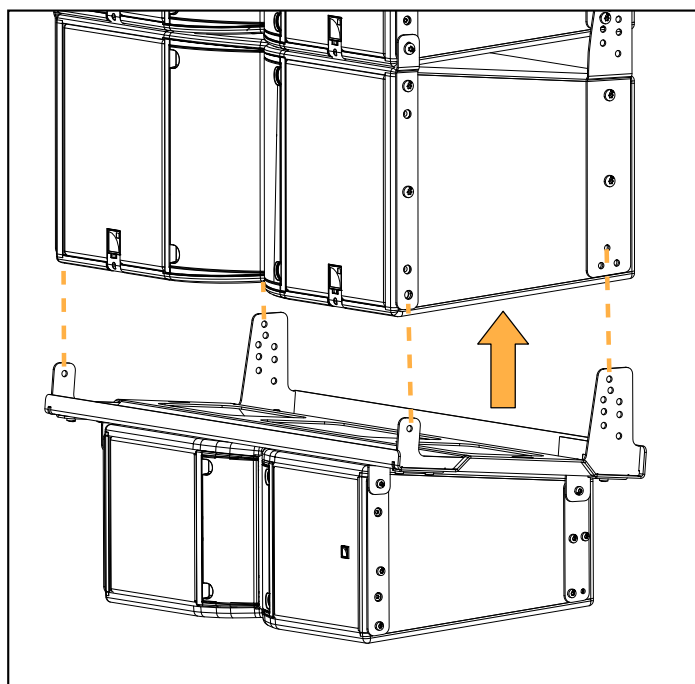

b) Link KARAlli-DOWNK3i at the front with rigging screws.

Do not fully tighten the screws.

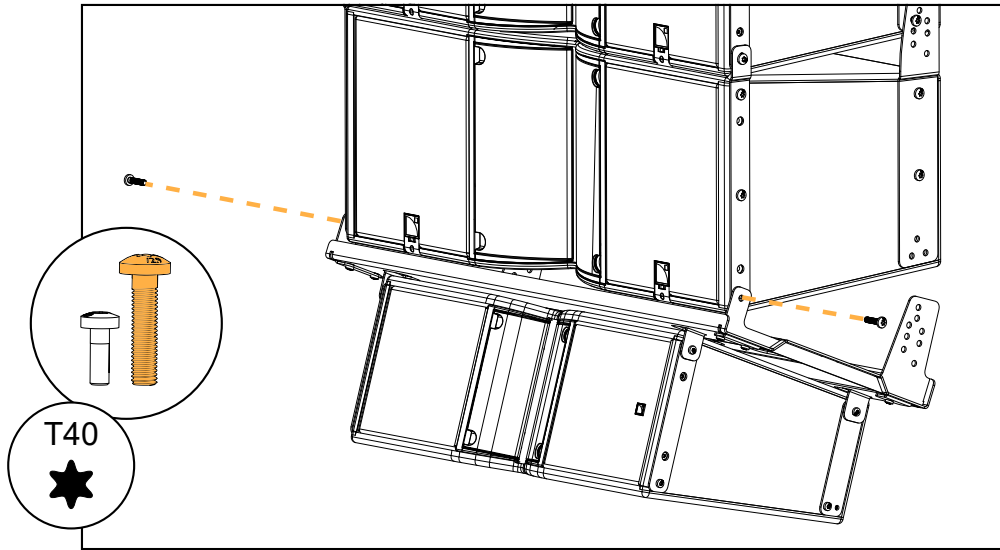

c) Link KARAlli-DOWNK3i at the rear with the rigging screws.

Select the appropriate holes and inserts depending on the selected angle. Apply a torque of 7 N.m.

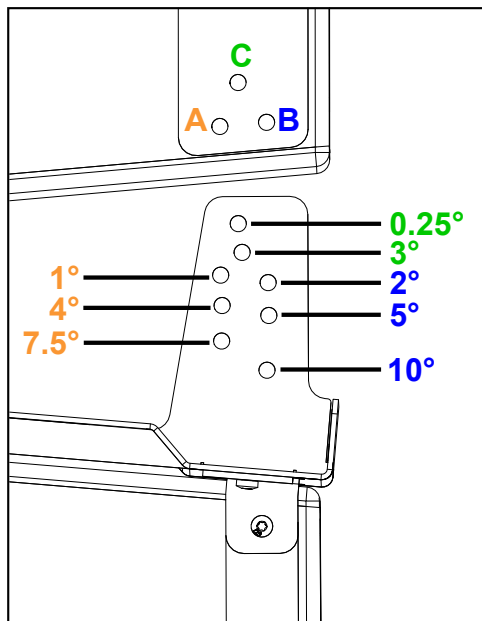
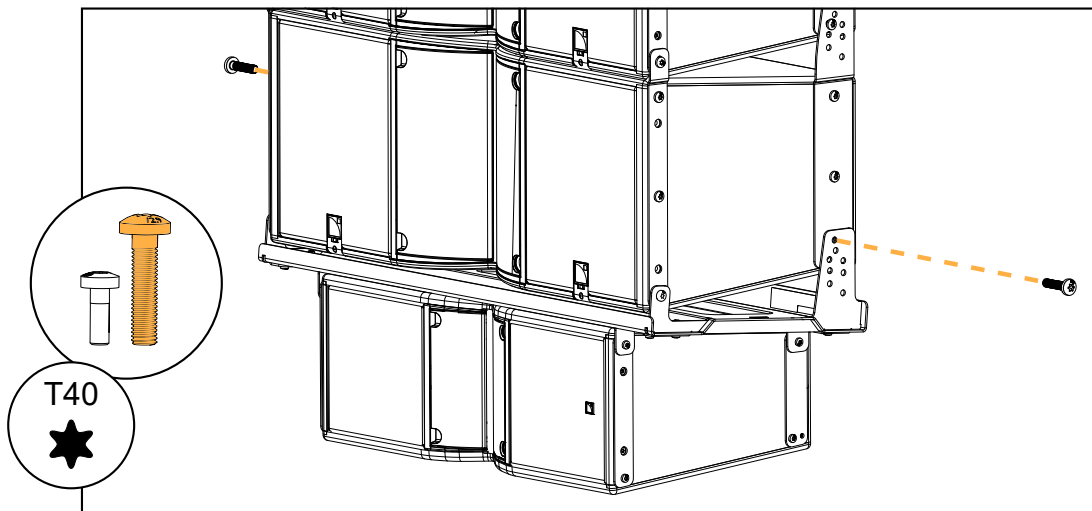

6. Tighten the screws of the bottom K3i enclosure on both sides. Apply a torque of 7 N.m.

7. Tighten the screws of the KARAlli-DOWNK3i assembly. Apply a torque of 5 N.m.
8. Raise the array.
9. Add more Kara Ili with KARAlli-LINK as necessary to complete the array.
10. Check that all screws are secured and tightened.

What to do next

To add screens to K3i, refer to [Securing a screen](#) (p.71).

To add screens to Kara Ili, refer to the **Kara Ili owner's manual**.

Ceiling-mounting a K3i array with K3i-CEILINGBRACKET

Type of deployment	ceiling-mounting
Rigging accessory	K3i-CEILINGBRACKET
Screws and fasteners	4 M8x35 rigging screws (provided)
Additional accessories	4 Ø10 mm screws and anchors
Tools	electric screwdriver with torque selector T40 Torx bit
Min number of operators	3

Rigging plates

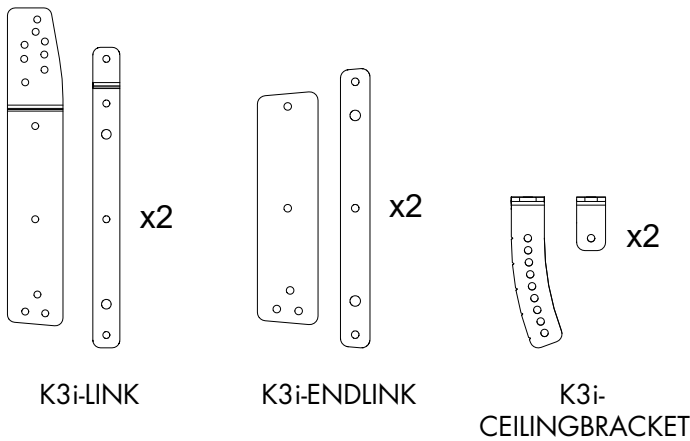

Site angles

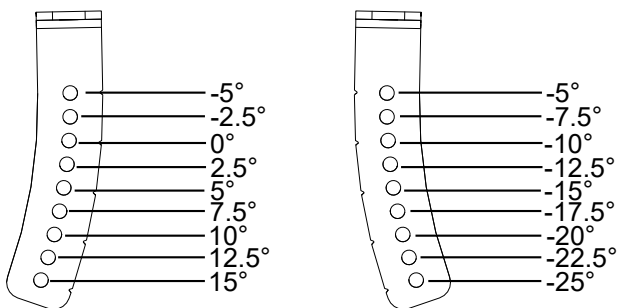

When used at the front, it is not possible to use K3i-SCREEN.



Fasteners for ceiling-mounting.

Select screw length and anchors applicable to the ceiling properties.
Model the array in Soundvision and check the loads on rigging in the **Mechanics** view.



Risk of falling objects

Verify that no unattached items remain on the product or assembly.

Procedure

- Secure K3i-CEILINGBRACKET to the ceiling using four M10 screws and fasteners.



Fasteners for ceiling-mounting.

Select screw length and anchors applicable to the ceiling properties.

Model the array in Soundvision and check the loads on rigging in the **Mechanics** view.

The ceiling holes are the centered hole (on the shorter side).

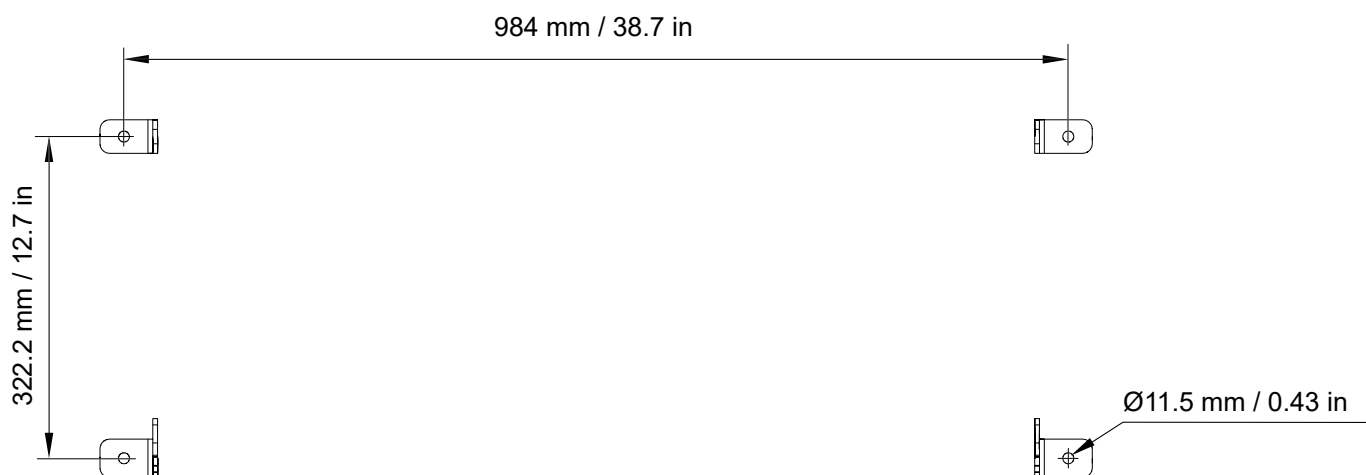
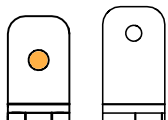

- On the first enclosure, remove the relevant placeholder screws on both sides.

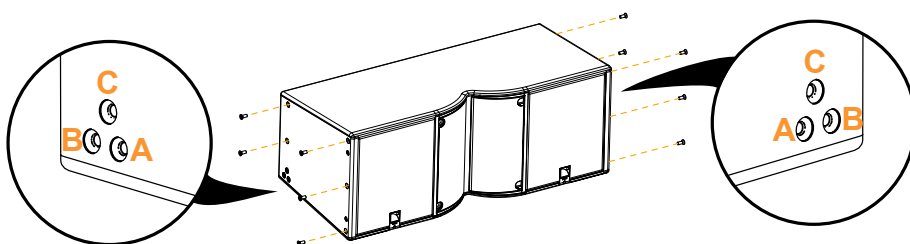

Risk of acoustic leaks

Do not remove the placeholder screws from the bottom rear inserts (A, B or C) that are not used.

rigging accessory	inter-element angles	used insert
K3i-LINK (connecting from an enclosure below) / KARAlli-DOWNK3i	0.25°, 3°	C
	2°, 5°, 10°	B
	1°, 4°, 7.5°	A
K3i-RIGBAR	—	B
K3i-TILTBRACKET	5°, 2.5°, 0°, -2.5°, -5°, -7.5°, -10°, -12.5°, -15°	A

It is recommended to use the rigging report from Soundvision to prepare the enclosures.

3. Secure the middle screws of K3i-ENDLINK on both sides.

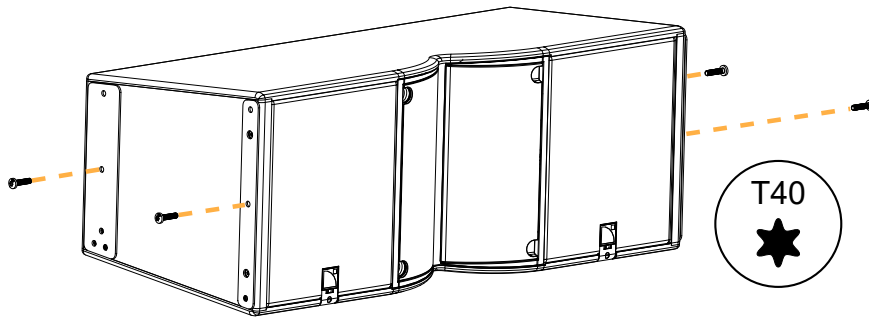

This step requires three operators.

Hold the enclosure at the bottom until the rigging plates are secured.

4. Secure the enclosure on K3i-CEILINGBRACKET with rigging screws:
 - a) Secure the enclosure to the short bracket.

K3i-CEILINGBRACKET must be on top of the plates of the enclosure.

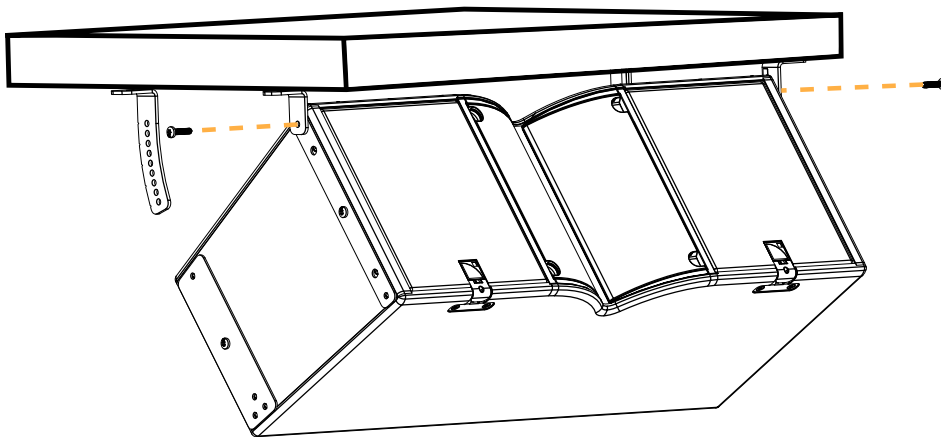
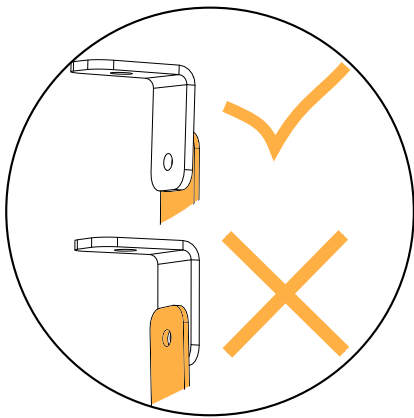

b) Secure the enclosure to the long bracket. Select the appropriate angle.

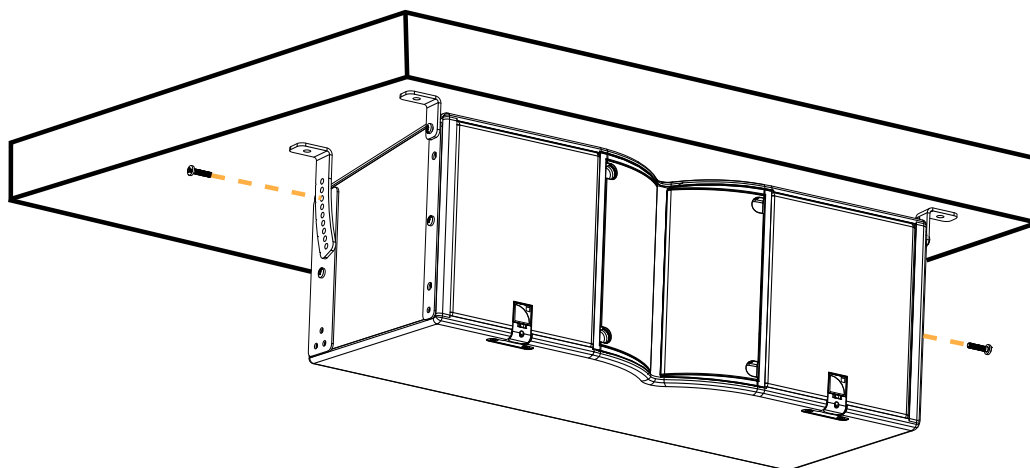

5. Depending on the selected deployment, add more K3i enclosures, one at a time:

- On the additional enclosure, remove the relevant placeholder screws, refer to step 2 (p.63).
- Secure the top and middle screws of K3i-LINK on both sides.

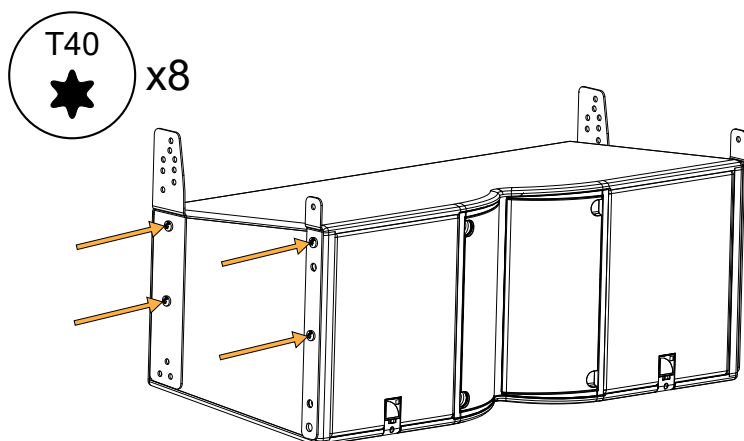

c) Lift the enclosure under the array and tighten the screws.

Select the appropriate holes and inserts depending on the selected angle.

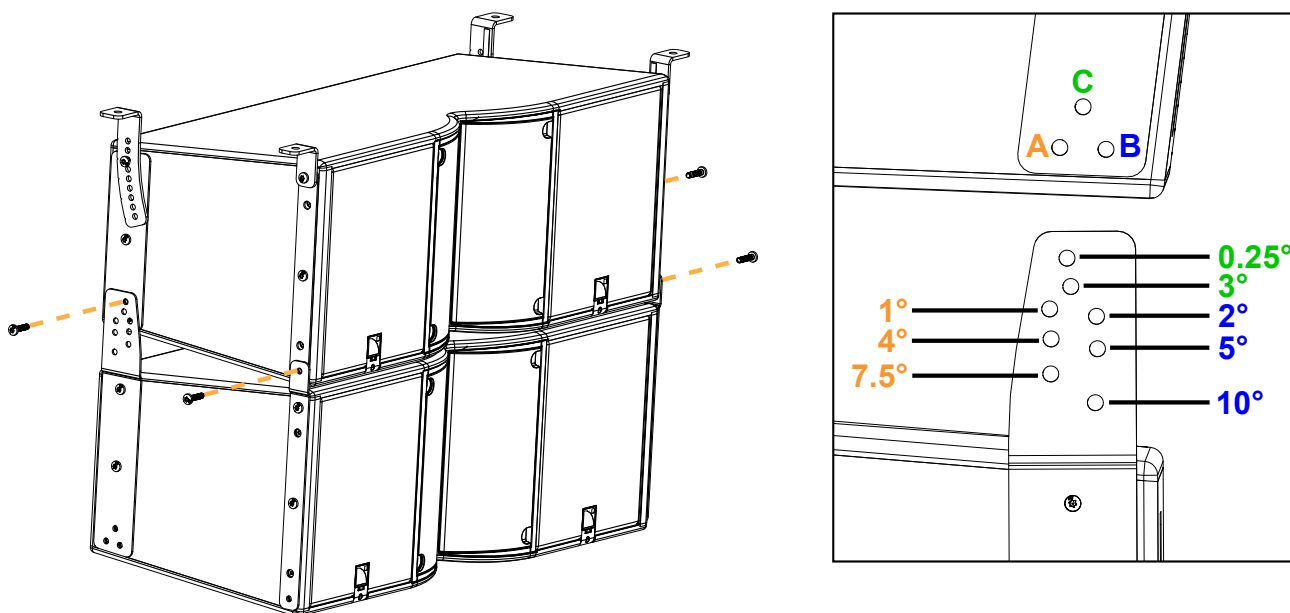

d) Tighten all the screws on the supporting enclosure.
Apply a torque of 7 N.m.

6. Tighten the bottom screws on the last enclosure.

Apply a torque of 7 N.m.

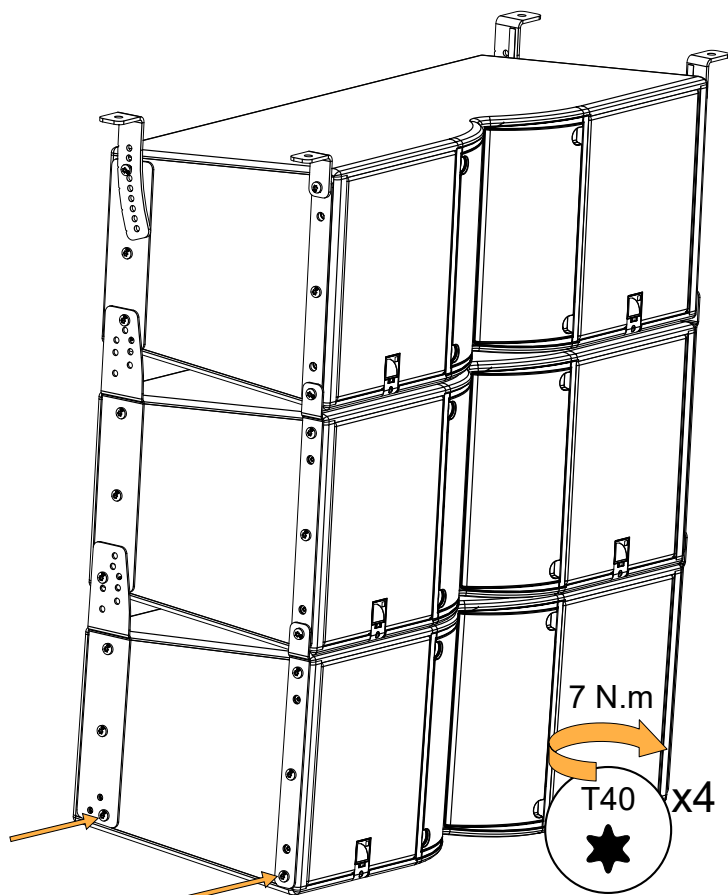

What to do next

To secure screens, refer to [Securing a screen](#) (p.71).

Stacking a K3i array on K3i-TILTBRACKET

Type of deployment	stacked array
Rigging accessory	K3i-TILTBRACKET
Screws and fasteners	4 M8x35 screws (provided)
Additional accessories	4 Ø10 mm screws and anchors
Tools	electric screwdriver with torque selector T40 Torx bit Wedges or other lever devices
Min number of operators	3

Rigging plates

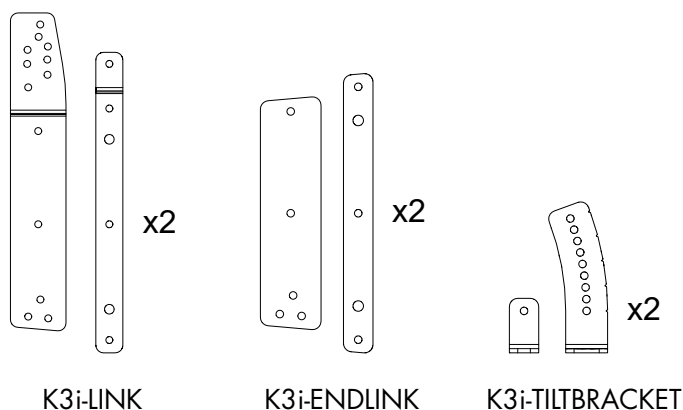

Site angles

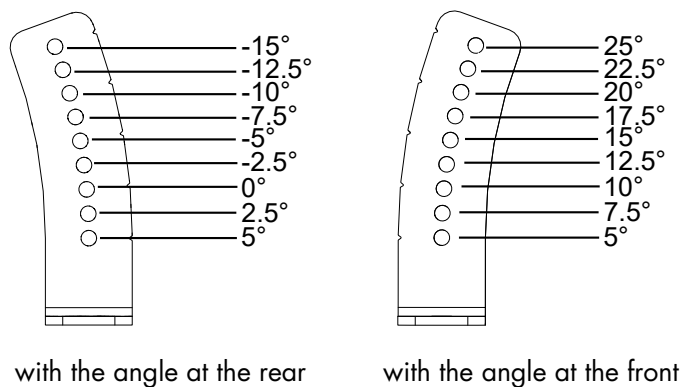

When used at the front, it is not possible to use K3i-SCREEN.

- ⚠ Fastening brackets**
Always secure a stacked array to the ground using K3i-TILTBRACKET to ensure the stability of the array.
- ⚠ Risk of falling objects**
Verify that no unattached items remain on the product or assembly.

Procedure

1. Secure K3i-TILTBRACKET to the ground using four screws and anchors.

Use the centered hole (on the smaller side).

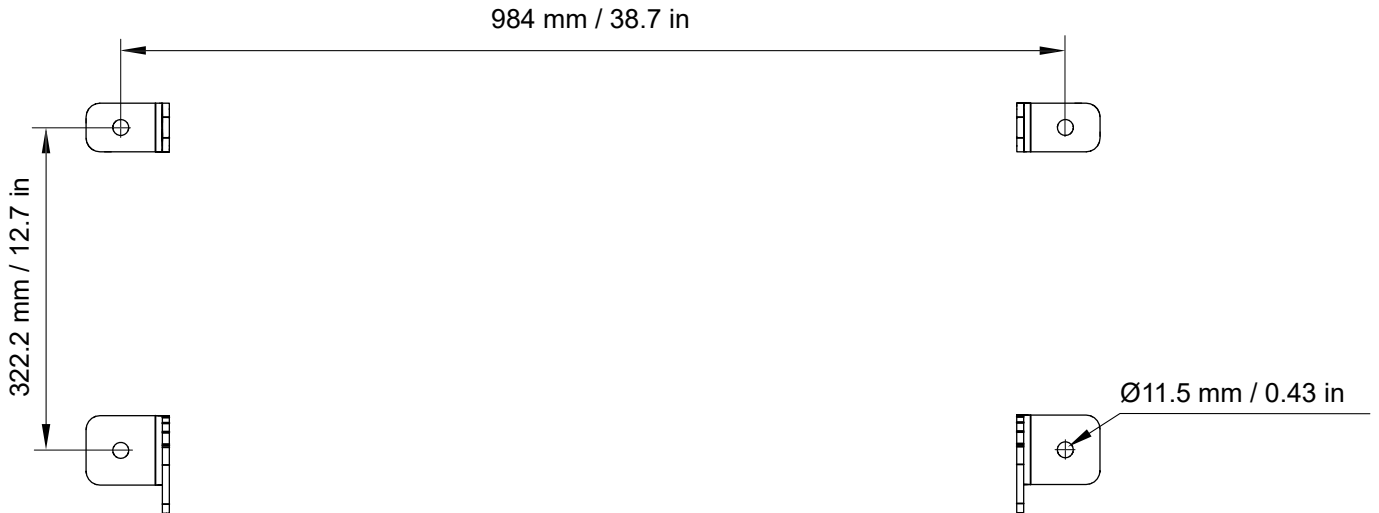
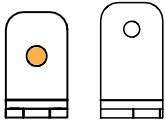

2. On the enclosure, remove the placeholder screws.

At the bottom rear, remove insert A.

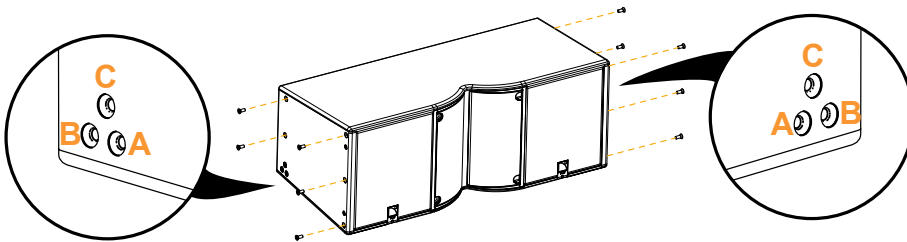

Risk of acoustic leaks

Do not remove the placeholder screws from the bottom rear inserts (B or C) that are not used.

3. Secure the top and middle screws of K3i-LINK on both sides.

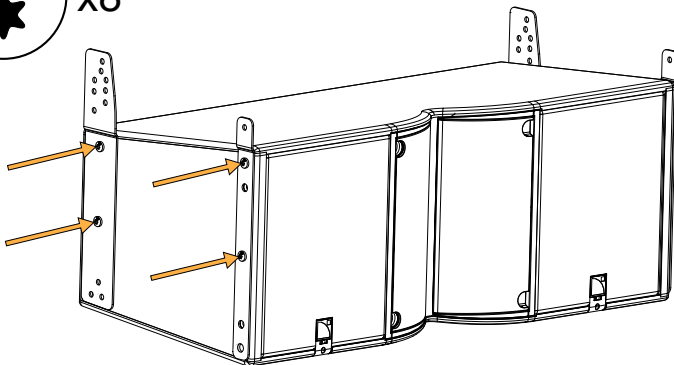
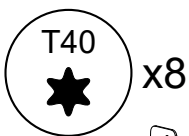



Risk of crushing injury

Keep fingers away from underneath the enclosure.

4. Position the enclosure inside K3i-TILTBRACKET.

K3i-TILTBRACKET must be on top of the plates of the enclosure.

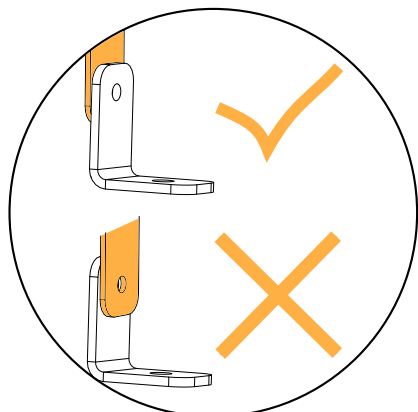

5. Use wedges or other lever devices to align the inserts and the holes, and tighten the screws.
Select the appropriate hole on the angle accessories.

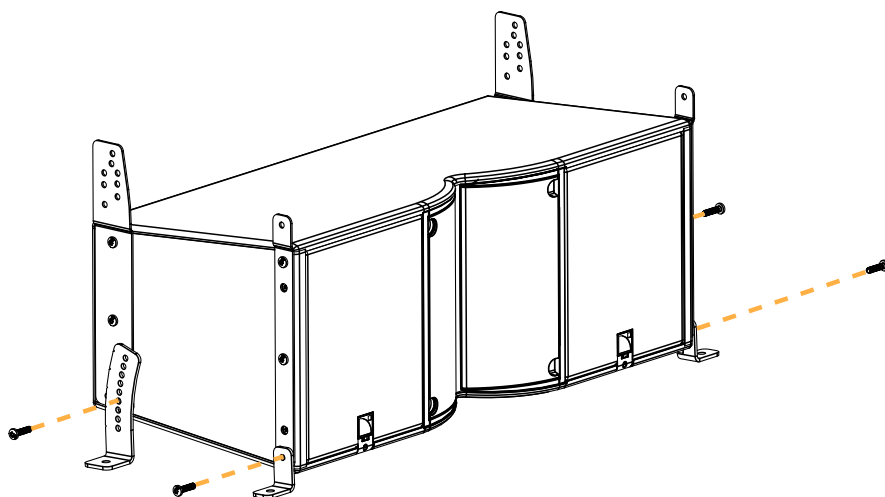

6. Depending on the selected deployment, add more K3i enclosures, one at a time:
 - a) On the additional enclosure, remove the relevant placeholder screws, refer to step 2 (p.68).
 - b) Secure the top and middle screw of the link on both sides.

For the last enclosure at the top of the stacked array, use K3i-ENDLINK, otherwise use K3i-LINK.

- c) **⚠ Risk of crushing injury**
 Keep fingers away from underneath the enclosure.
 Lift the enclosure and position it on top of the stacked array.

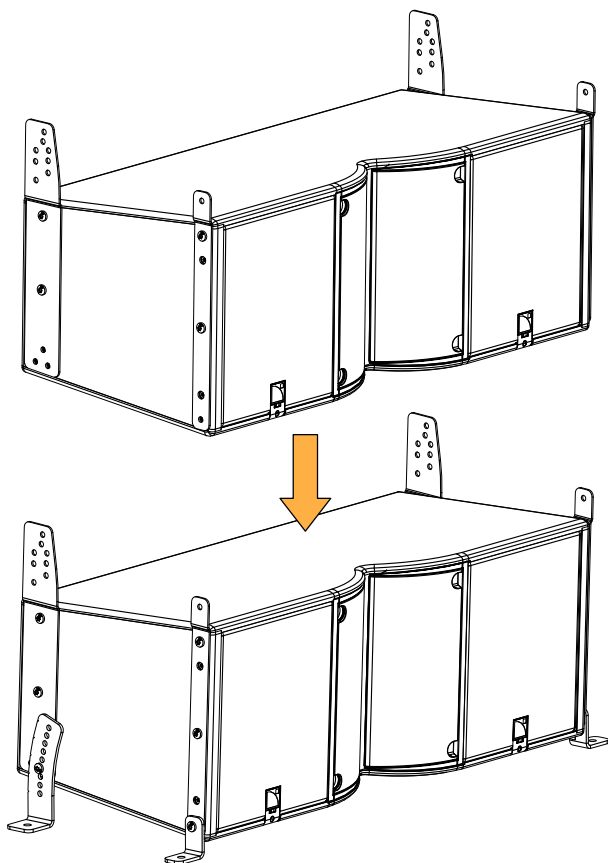

- d) Use wedges or other lever devices to align the inserts and the holes, and tighten the screws.
 Select the appropriate hole on the angle accessories.

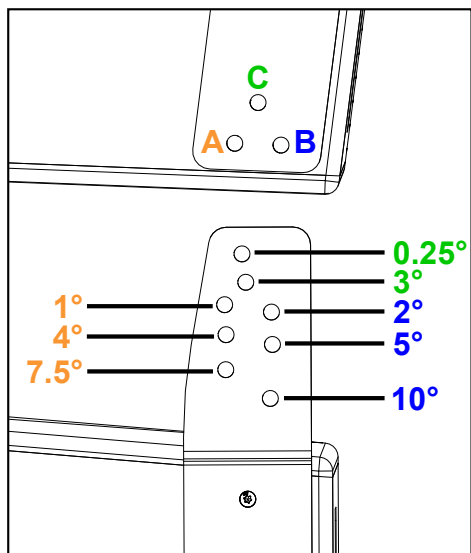

- e) Tighten all the screws on the supporting enclosure.
 Apply a torque of 7 N.m.

7. Check that all the screws are secured and tightened.

What to do next

To secure screens, refer to [Securing a screen](#) (p.71).

Securing a screen

Rigging accessory	K3i-SCREEN
Screws and fasteners	4 M6x25 screws (provided) 4 self-sticking M6 washers (for configurations with no rigging plates, provided)
Tools	electric screwdriver with torque selector T30 Torx bit
Min number of operators	1

⚠ Risk of falling objects
Verify that no unattached items remain on the product or assembly.

i Secure the screens on the enclosures after the array is fully assembled.

Procedure

1. Remove the placeholder screws through the rigging plates on both side.

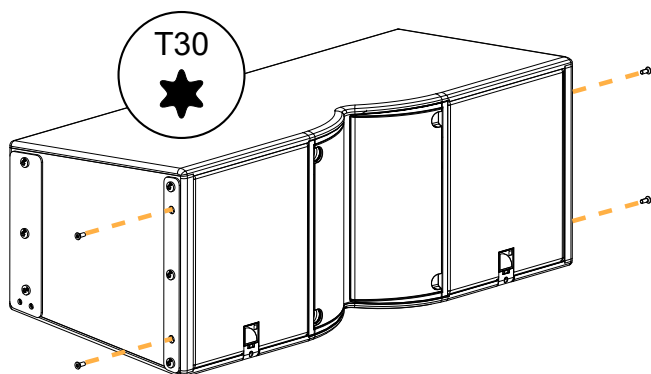

⚠ Risk of bending screen fixing tabs
Always use the self-sticking washers for securing a screen when there are no rigging plates on the enclosure.

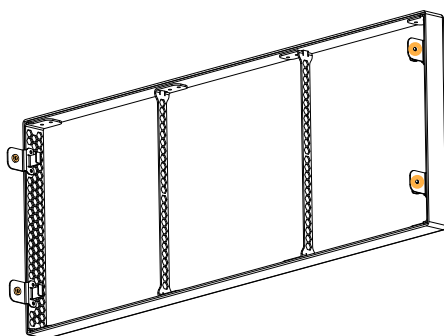

2. Secure the screen. Apply a torque of 5 N.m.

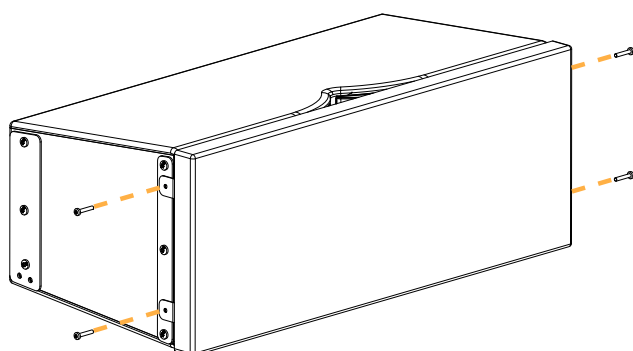

Connection to LA amplified controllers

Enclosure drive capacity per amplified controller

Make sure the total number of connected enclosures does not exceed the maximum number of enclosure per controller (refer to the footnote).

	LA2Xi	LA4X	LA8	LA12X
	per output[*] / total	per output[*] / total	per output[*] / total	per output[*] / total
K3i	—	1 / 2	2 / 4	3 / 6
Kara Ili	2 / 4 (SE)	2 / 4	3 / 6	3 / 6

i Reduced maximum SPL or drive capacity with LA2Xi: refer to the **LA2Xi owner's manual**.

Refer to the cabling schemes to connect the enclosures to different types of output connectors.

! Refer to the cable manufacturer documentation for the wire color code.

Cabling schemes

For K3i / Kara Ili

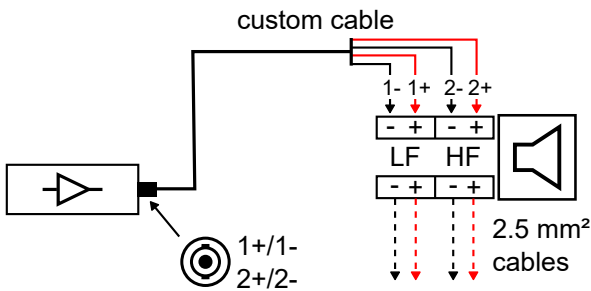

Refer to the **Kara Ili owner's manual** for the cabling schemes of Kara Ili with LA2Xi.

* For passive loudspeakers, the value corresponds to the number of enclosures in parallel on the output. For active loudspeakers, the value corresponds to the number of sections in parallel on the output.

Cabling

Accessory	connector sealing plate (provided)
Screws and fasteners	4 M5×16 screws (provided)
Tools	torque screwdriver T25 Torx bit small tool or flat screwdriver (3 mm or less)
Min number of operators	1

Assembly

Prerequisite



The cable glands on the connector sealing plates are compatible with cables up to 4 × 4 mm² gauge.

Refer to:

- [APPENDIX A: Recommendation for speaker cables](#) (p.105)
- [Cabling schemes](#) (p.72)

About this task

The connector sealing plates have two cable glands: one for the input cable and one for the cable connecting to the next enclosure in parallel. The second cable gland is equipped with a protective plug.

This procedure describes how to connect the input cable to the enclosure. If the enclosure must be connected in parallel, remove the protective plug from the second cable gland and proceed identically for both cables.

Procedure

1. On the connector sealing plate, remove the sealing nut from the cable gland.

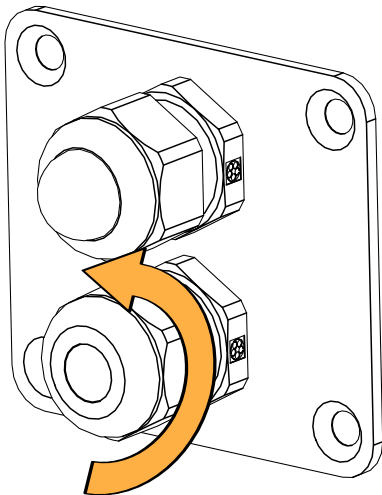

2. Insert the cable through the sealing nut and the cable gland.

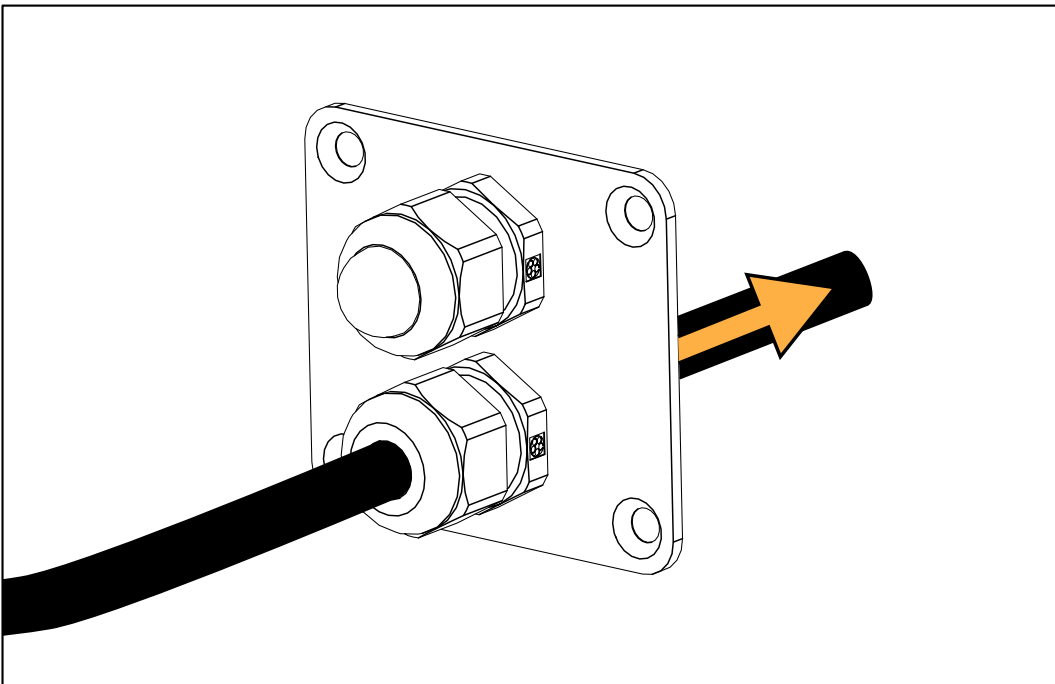
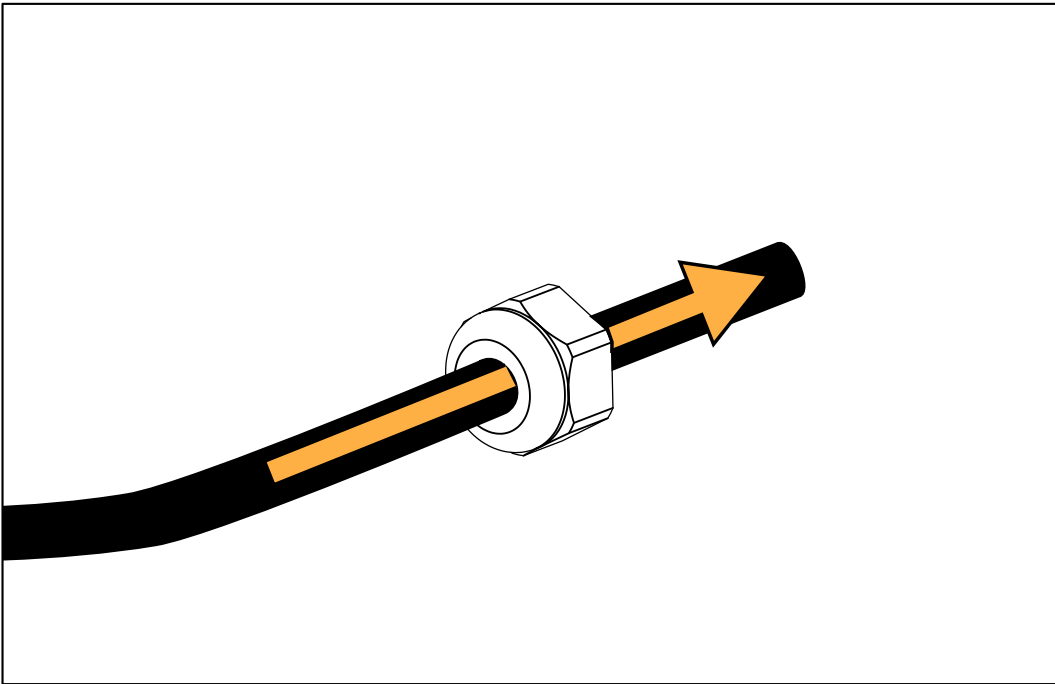

3. Strip the wires of the cable.

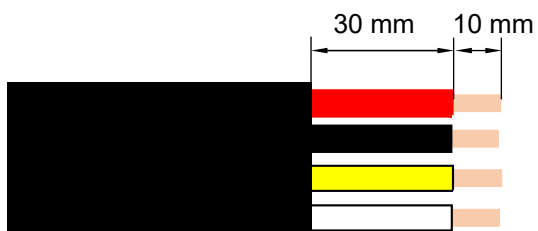

4 x 2.5 mm² cable

! Refer to the cable manufacturer documentation for the wire color code.

4. Push the wires into the terminals.

If necessary, use a small tool in the hole next to the terminal to unlock it.

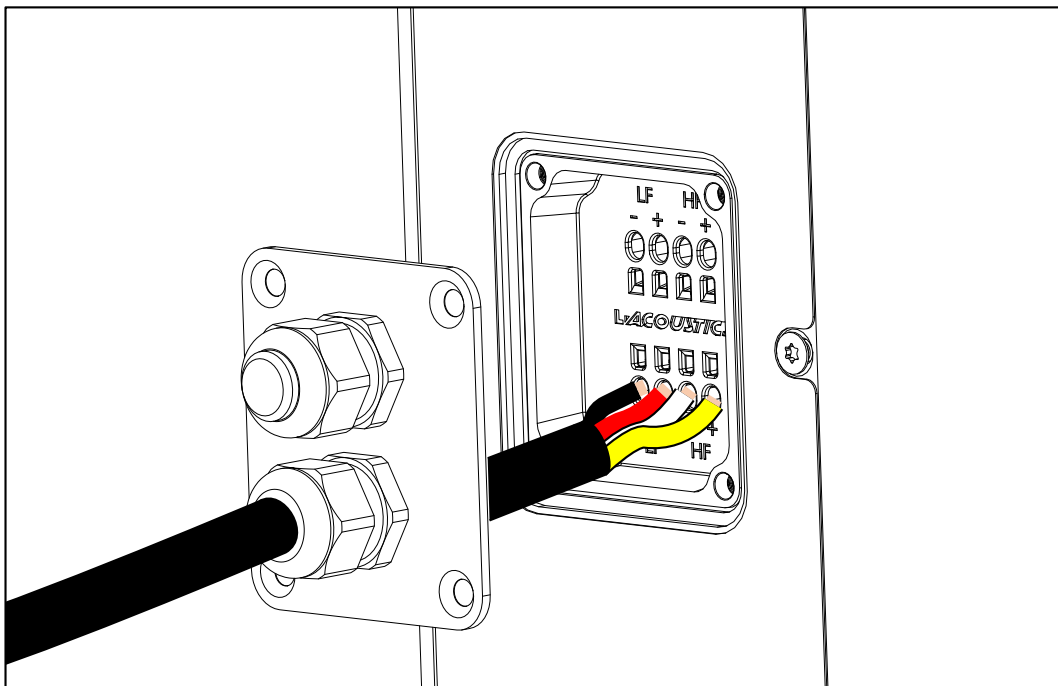

5. Secure the connector sealing plate to the connector plate.

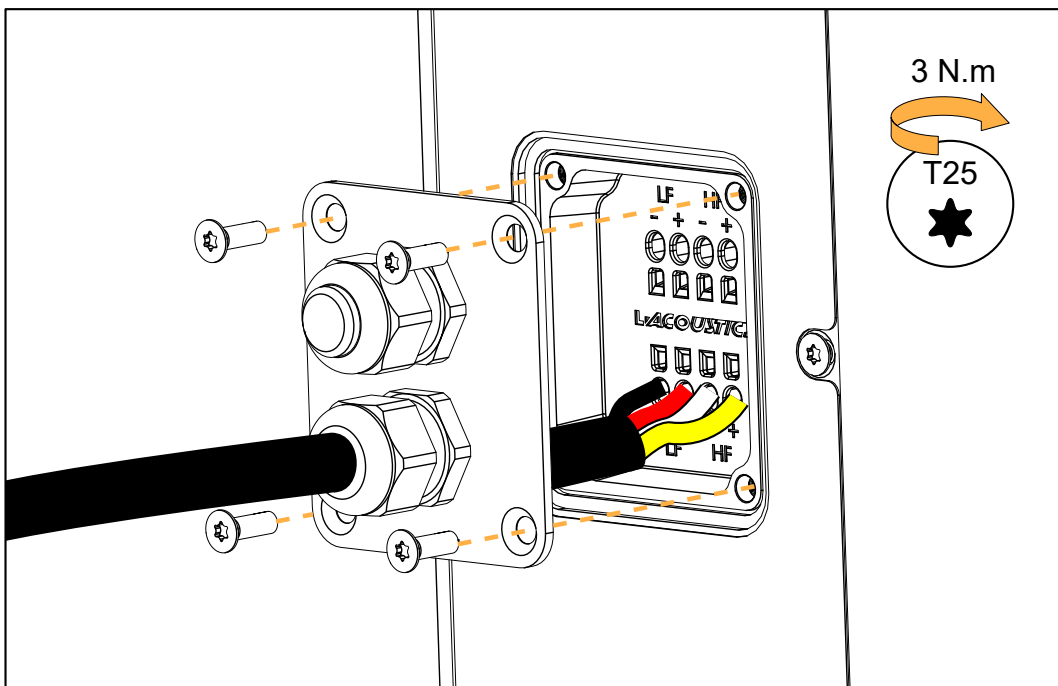

6. Tighten the sealing nut.

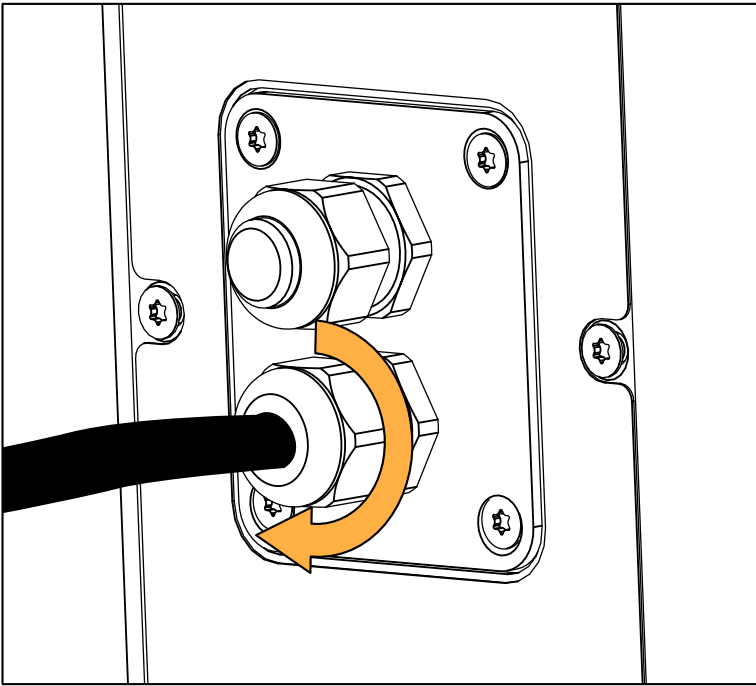

What to do next

To remove the cables use the small tool to unlock the terminals and pull on the wires.

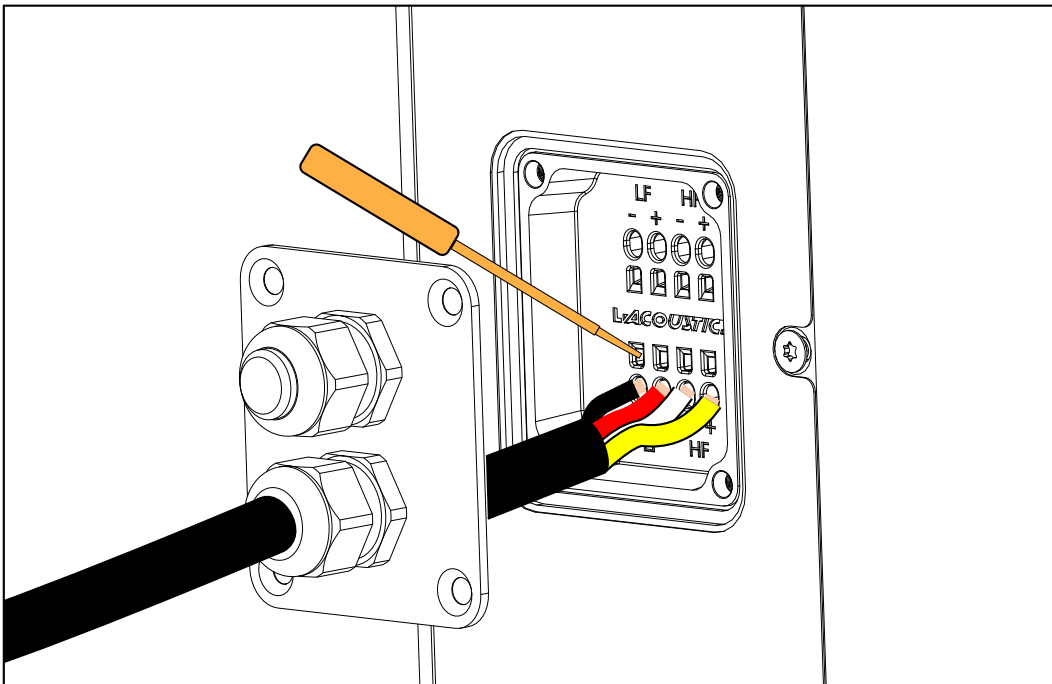

Corrective maintenance

Introduction

This section contains the following maintenance procedures:

- [D/R - Grill](#) (p.80)
- [D/R - Fin](#) (p.83)
- [D/R - LF speaker](#) (p.84)
- [D/R - Connector plate](#) (p.85)
- [D/R - HF driver](#) (p.86)
- [D/R - HF diaphragm](#) (p.87)

For advanced maintenance, contact your L-Acoustics representative.

Tools and consumables

Before performing maintenance on this product, make sure all the tools listed are available. References are given for FACOM® products in this table. Other manufacturers can be used.

name	reference	distributor
set of 6-point 1/4" sockets *	RL.NANO1 / R.360NANO	FACOM
torque screwdriver	A.404	FACOM
flat plastic tool	—	—
compressed air blower	—	—
double face adhesive tape	—	—



* included in the L-Acoustics Maintenance Toolcase.

Maintenance Toolcase

The Maintenance Toolcase is a carry-on suitcase that includes all the tools required to perform maintenance on L-Acoustics products. This toolcase is aimed at Certified Providers.

The Maintenance Toolcase uses a Peli™ 1510 Protector case that features three pre-cut layers of foam to safely fit the tools. The Maintenance Toolcase includes tools manufactured by FACOM®, Fluke®, Tohnichi, ABUS, and Würth.



All third-party trademarks, registered trademarks, or product names are the property of their respective owners.

K3i

Exploded views

In order to operate, follow the order outlined here. Each assembly refers to the corresponding Disassembly/Reassembly (D/R) procedure and the necessary repair kit.

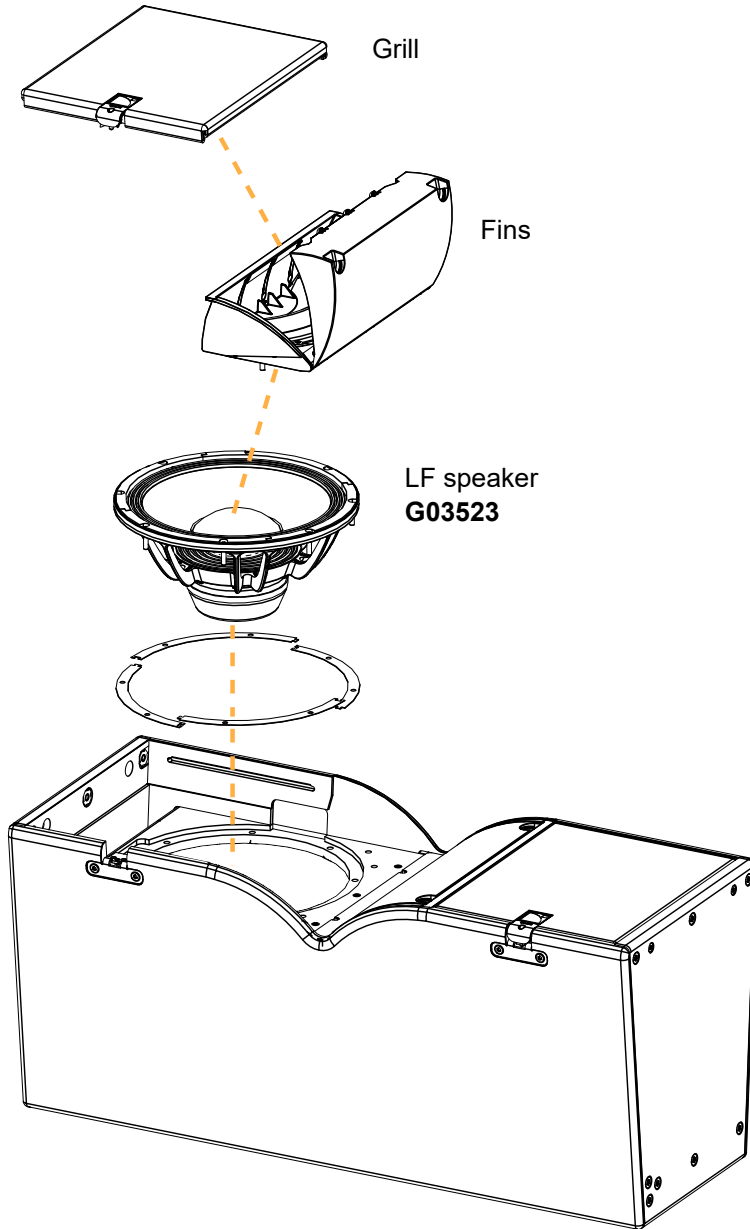

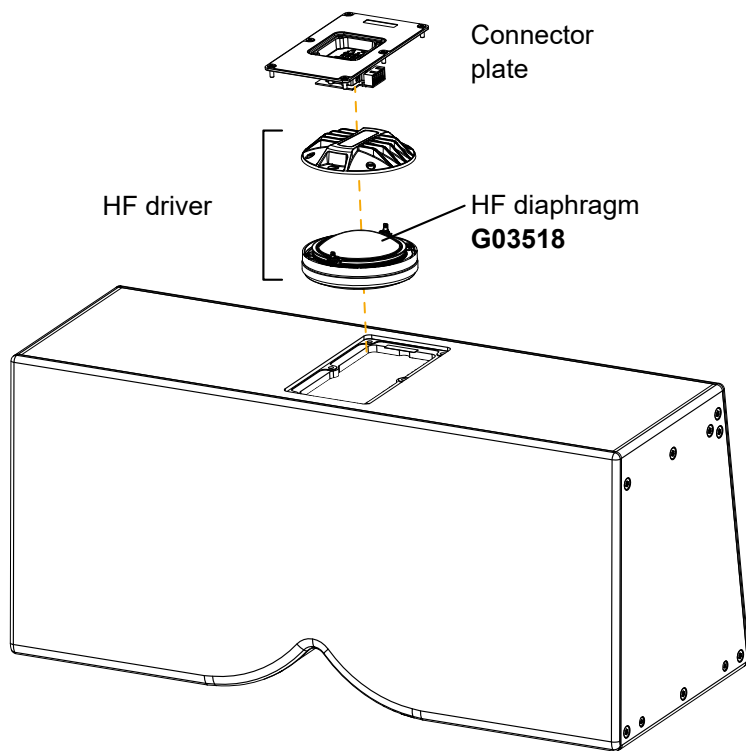

Disassembly and Reassembly procedures

D/R - Grill

Tools

- torque screwdriver
- T25 Torx bit

Disassembly

Procedure

1. Loosen the captive screw at the bottom of the grill.

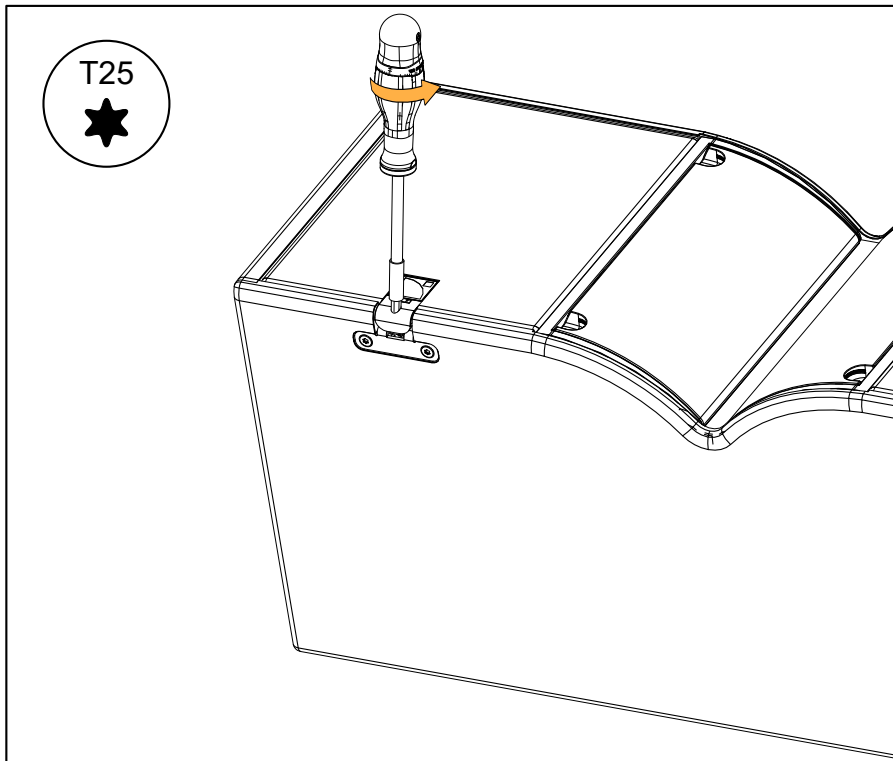

2. Push on the safety hook towards the right to release the grill.

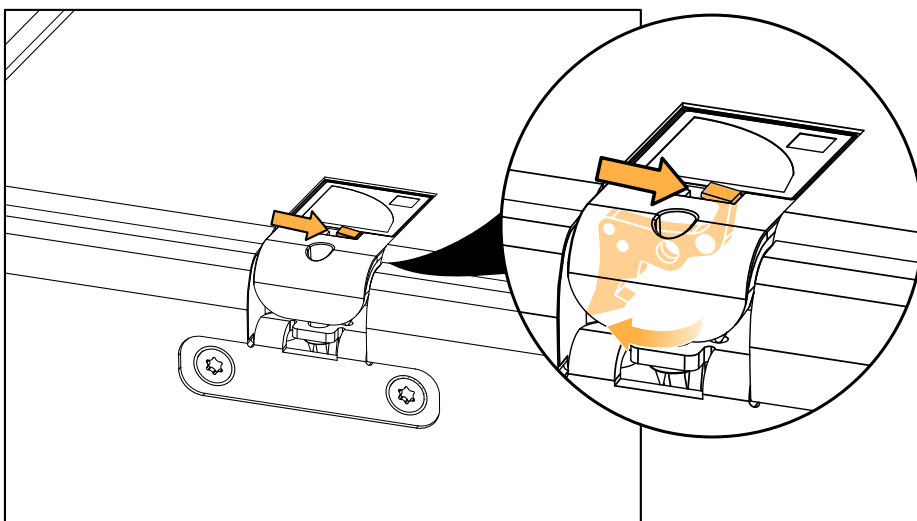

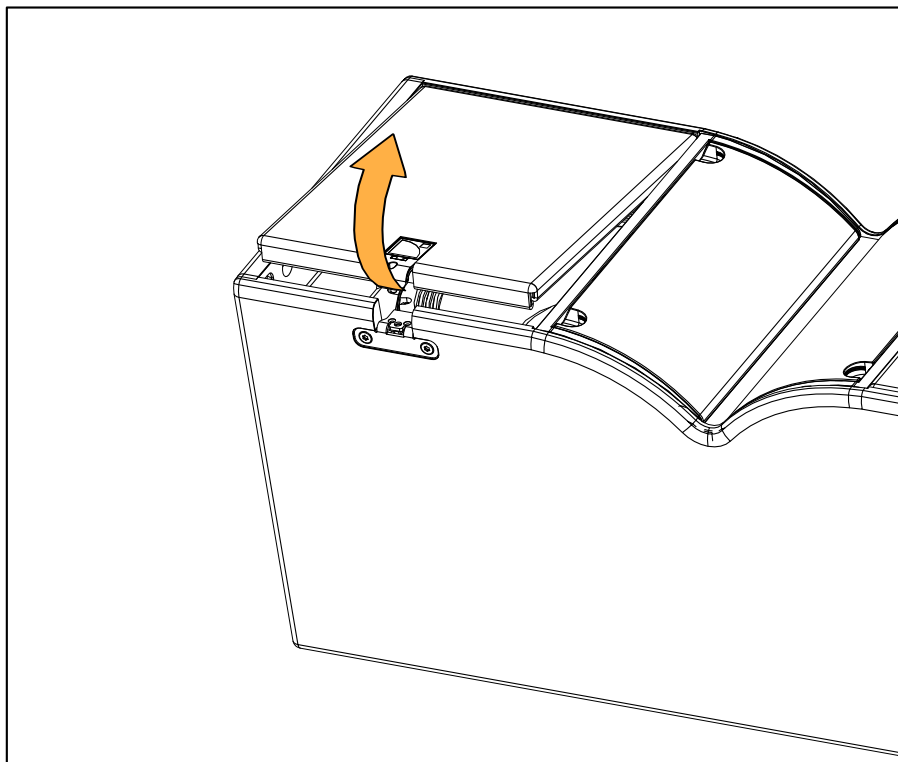
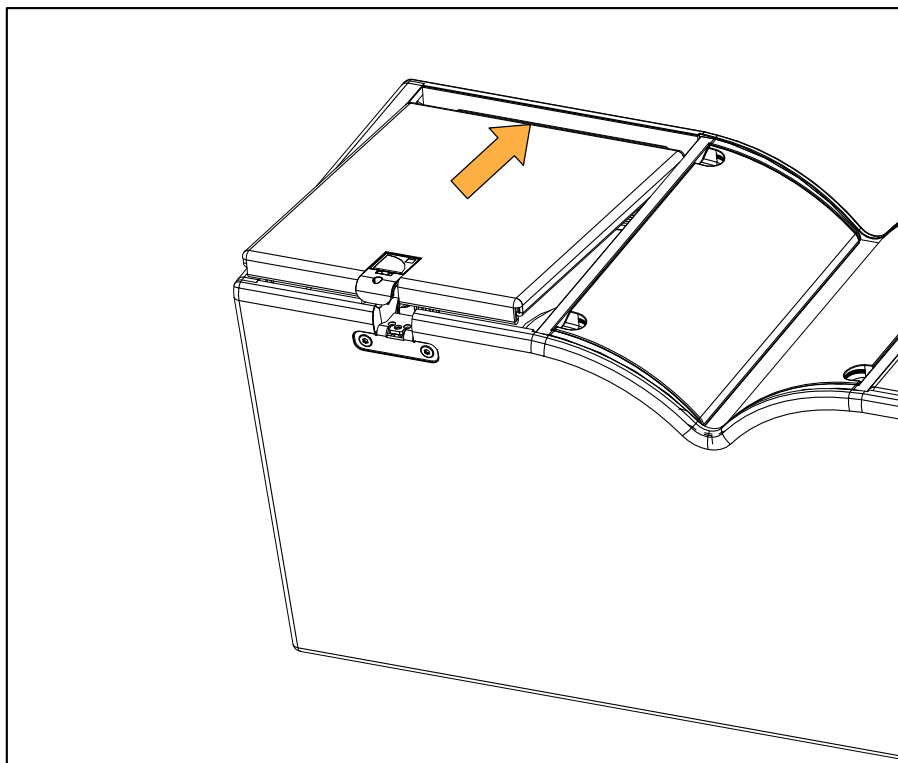
3. Remove the grill.**Reassembly****Procedure****1. Insert the top of the grill.**

2. Push the grill into place.

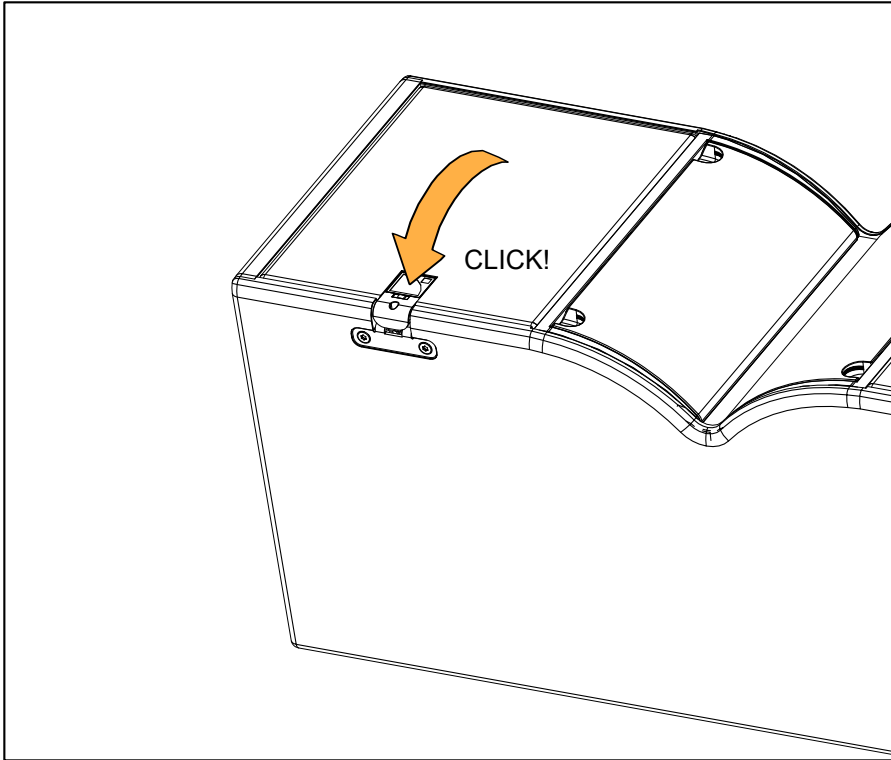

3. Tighten the captive screw.

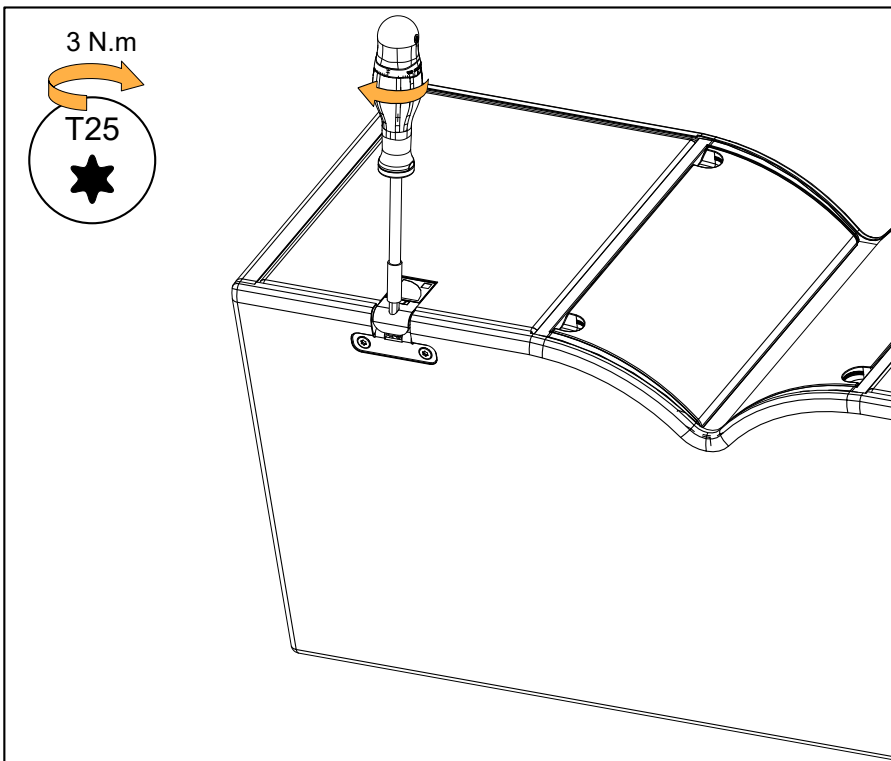

D/R - Fin**Tools**

- torque screwdriver
- T30 Torx bit
- flat plastic tool

Repair kit**G03523**

KR HP 12" K3(i) - 8 ohms

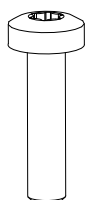

x12

S100143

M6x25 Torx

Exploded view

For safety reasons, always use the new screws and spare parts provided in the KR.
If no new screws are available, use blue threadlocker.



Use a flat tool made of **smooth plastic** to avoid scratching the fins.

Use the flat tool to unhook the fin clips.

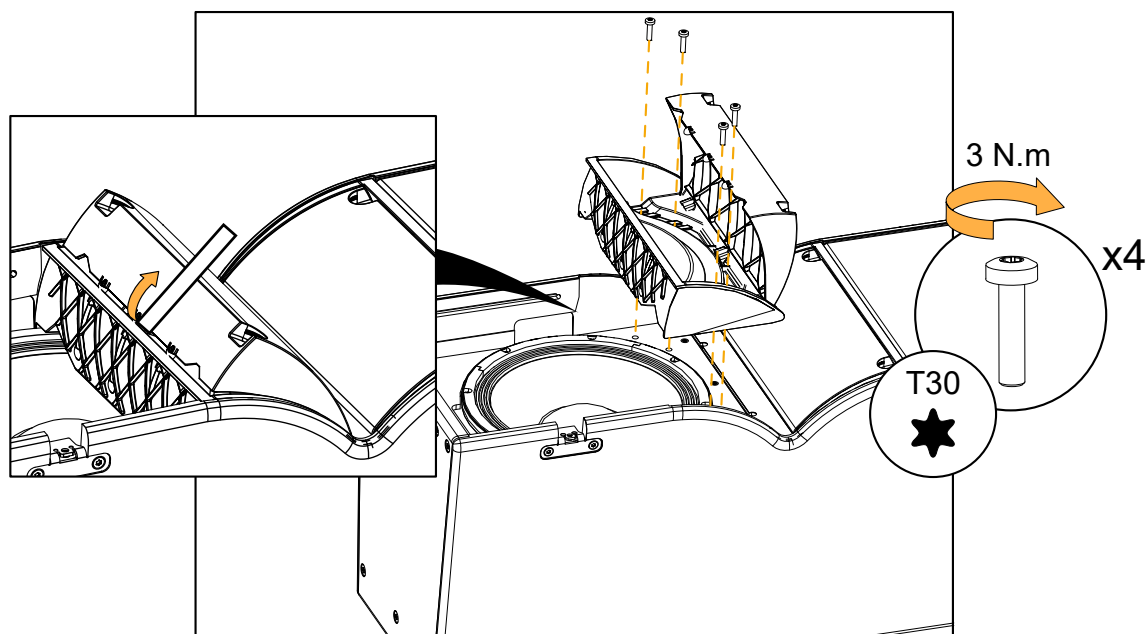

D/R - LF speaker

Tools

- torque screwdriver
- T30 Torx bit

Repair kit

G03523

KR HP 12" K3(i) - 8 ohms

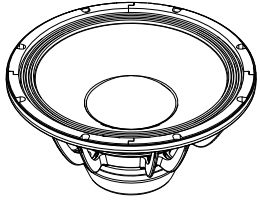

x1

18090

12" LF speaker - 8 Ω

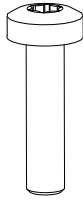

x12

S100143

M6x25 Torx

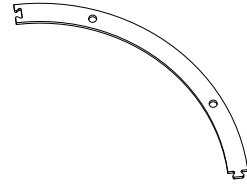

x4

1250

12" speaker gasket

Prerequisite

Grill removed.

See [D/R - Grill](#) (p.80).

Fin removed.

See [D/R - Fin](#) (p.83).

Exploded view

- ❗ For safety reasons, always use the new screws and spare parts provided in the KR. If no new screws are available, use blue threadlocker.
- ❗ Gradually tighten the screws following a star pattern.

Position the connectors towards the side of the enclosure.

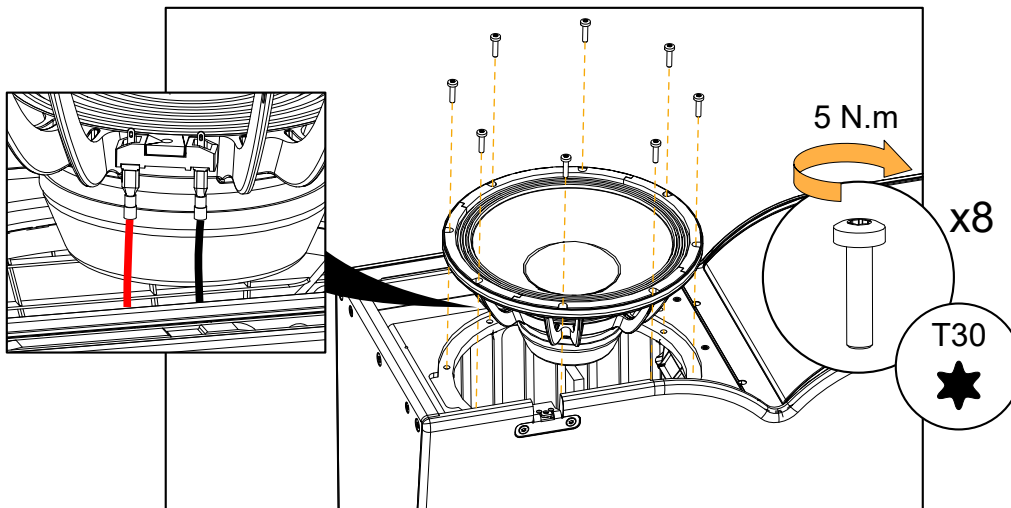

- i** If the speaker gasket is damaged, remove and replace it.

What to do next

Perform the [Acoustical check](#) (p.42) procedures.

D/R - Connector plate

Tools

- torque screwdriver
- T25 Torx bit
- flat plastic tool

Repair kit

G03518 - KR diaphragm 4" K3(i) or

G03522 - KR HP K3(i) Driver 4" - 8 ohms

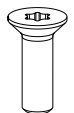

x6

S100086

M5x16 Torx

Exploded view



For safety reasons, always use the new screws and spare parts provided in the KR.
If no new screws are available, use blue threadlocker.



Gradually tighten the screws following a star pattern.

Use a flat tool as a lever to remove the connector plate.

Position the connector plate with the serial number label towards the bottom of the enclosure.

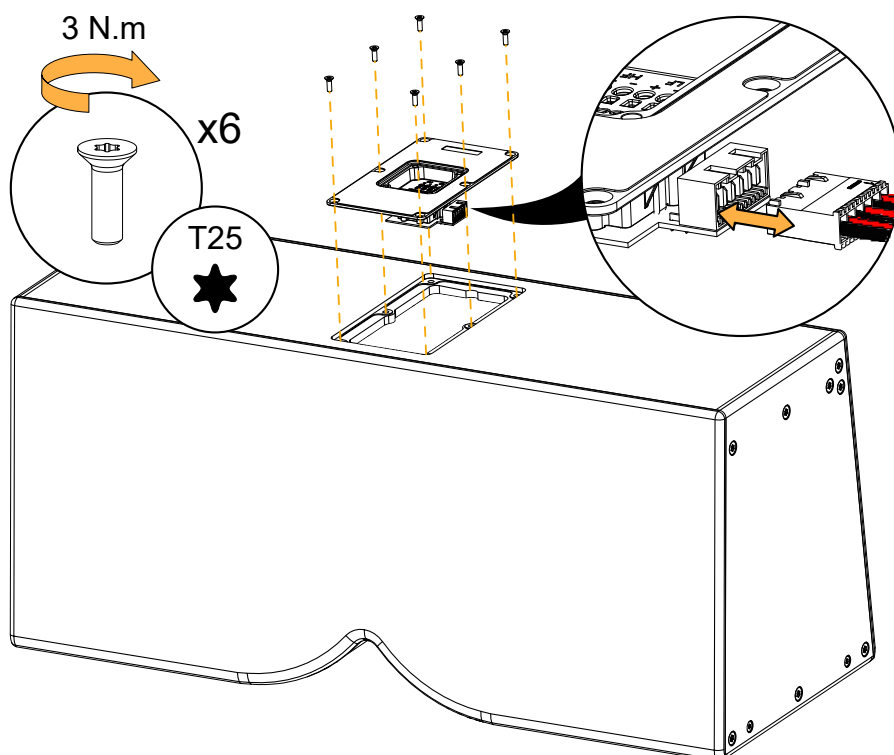

D/R - HF driver

Tools

- torque screwdriver
- T30 Torx bit

Repair kit

G03522*

KR HP K3(i) Driver 4" - 8 ohms

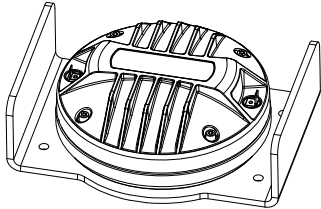

x1

18117

4" HF driver assembly - 8 Ω

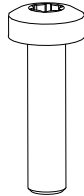

x4

S100143

M6x25 Torx



* The screws and fasteners are also provided in the G03518 (KR diaphragm 4" K3(i))

Prerequisite

Connector plate removed.

See [D/R - Connector plate](#) (p.85).

Exploded view



For safety reasons, always use the new screws and spare parts provided in the KR.
If no new screws are available, use blue threadlocker.

Carefully disconnect the cables before removing the driver assembly.

Use the positive (red) connector as a reference point to position the driver assembly.

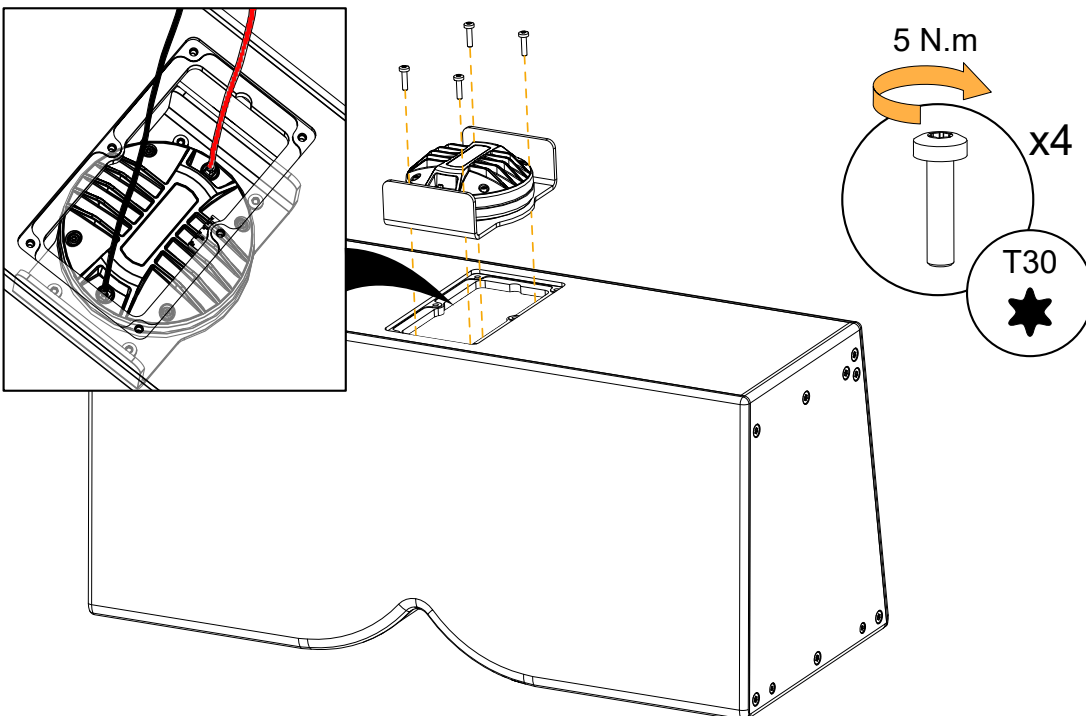

D/R - HF diaphragm

Tools

- torque screwdriver
- 4 mm hex bit
- compressed air blower

Consumables

- double face adhesive tape

Repair kit

G03518

KR diaphragm 4" K3(i)

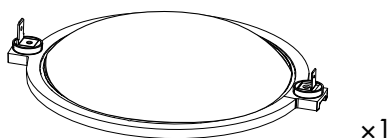

18189

diaphragm assembly (with shims)

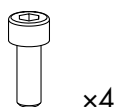

S100258

M5x14 hex

Prerequisite

! Always remove the HF driver from the cabinet before attempting to replace the diaphragm.

Connector plate removed.

HF driver removed from the cabinet.

The driver is placed on a flat surface in a dust-free environment.

See [D/R - Connector plate](#) (p.85).

See [D/R - HF driver](#) (p.86).

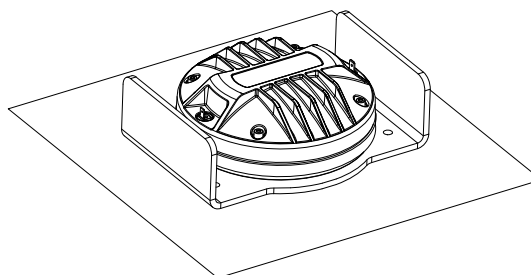

Disassembly

Procedure

1. Remove the four screws securing the cover.
Use the 4 mm hex bit.
2. Remove the cover.
3. Carefully remove the diaphragm.
4. If there are shims on the dome, carefully remove them.
Take note of how many and what kind of shims are present.

Reassembly

About this task

- ❗ For safety reasons, always use the new screws and spare parts provided in the KR.
- ❗ **Incorrect reassembly can cause acoustical issues and irreversible damage.**
It is important, even for maintenance experts, to carefully read and apply these steps.

Procedure

1. Clean the dome and the air gap.
 - ❗ **Make sure the air gap is perfectly clean before reassembly.**
Use a blower or double face adhesive to remove any particle.
2. Place the same kind and number of shims that were initially present.
3. Carefully place the diaphragm, and adjust the position using the positive (red) connector as reference point.

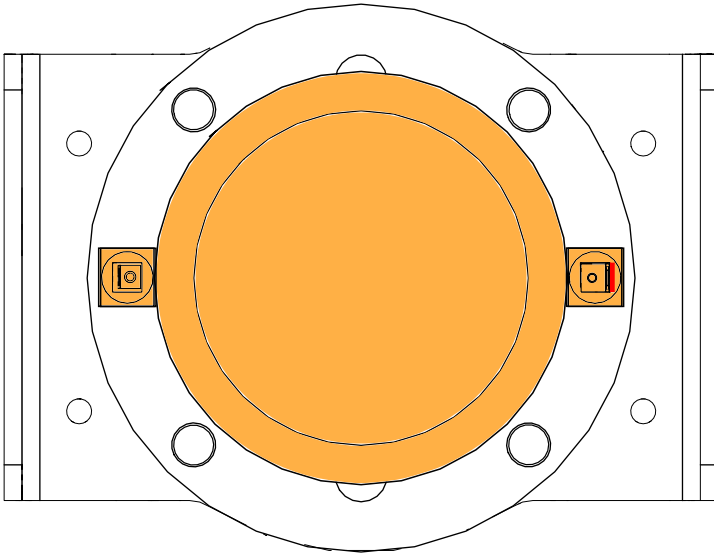

4. Position the cover and check the alignment with the screw holes.
If needed, turn both the cover and the diaphragm together to adjust the position.
5. Make sure that the metal terminal tabs do not touch the cover.

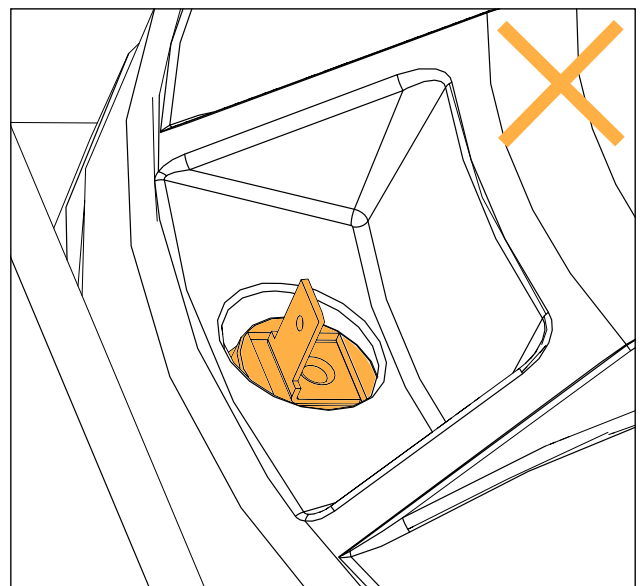
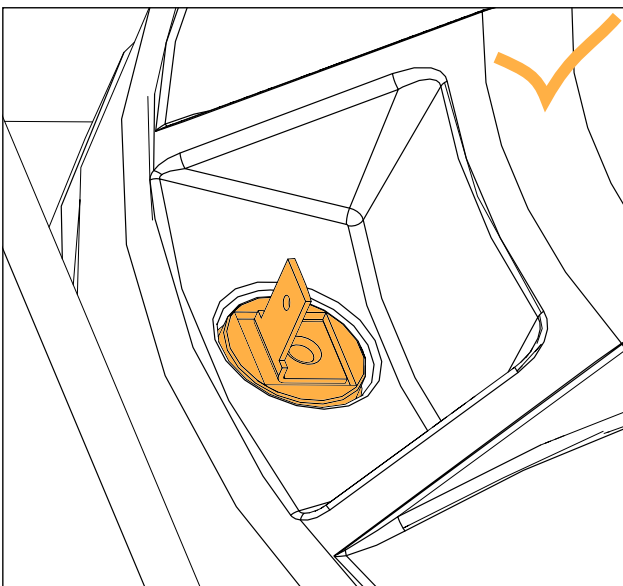

6. Secure the diaphragm:
- Maintain the diaphragm into position by pressing down on the center.
 -  Gradually tighten the screws following a star pattern.

Secure the bottom-right screw without tightening, then tighten the remaining screws as illustrated, then fully tighten the bottom-right screw.

Use four S100258 screws with the 4 mm hex bit. Set the torque to 3 N.m.

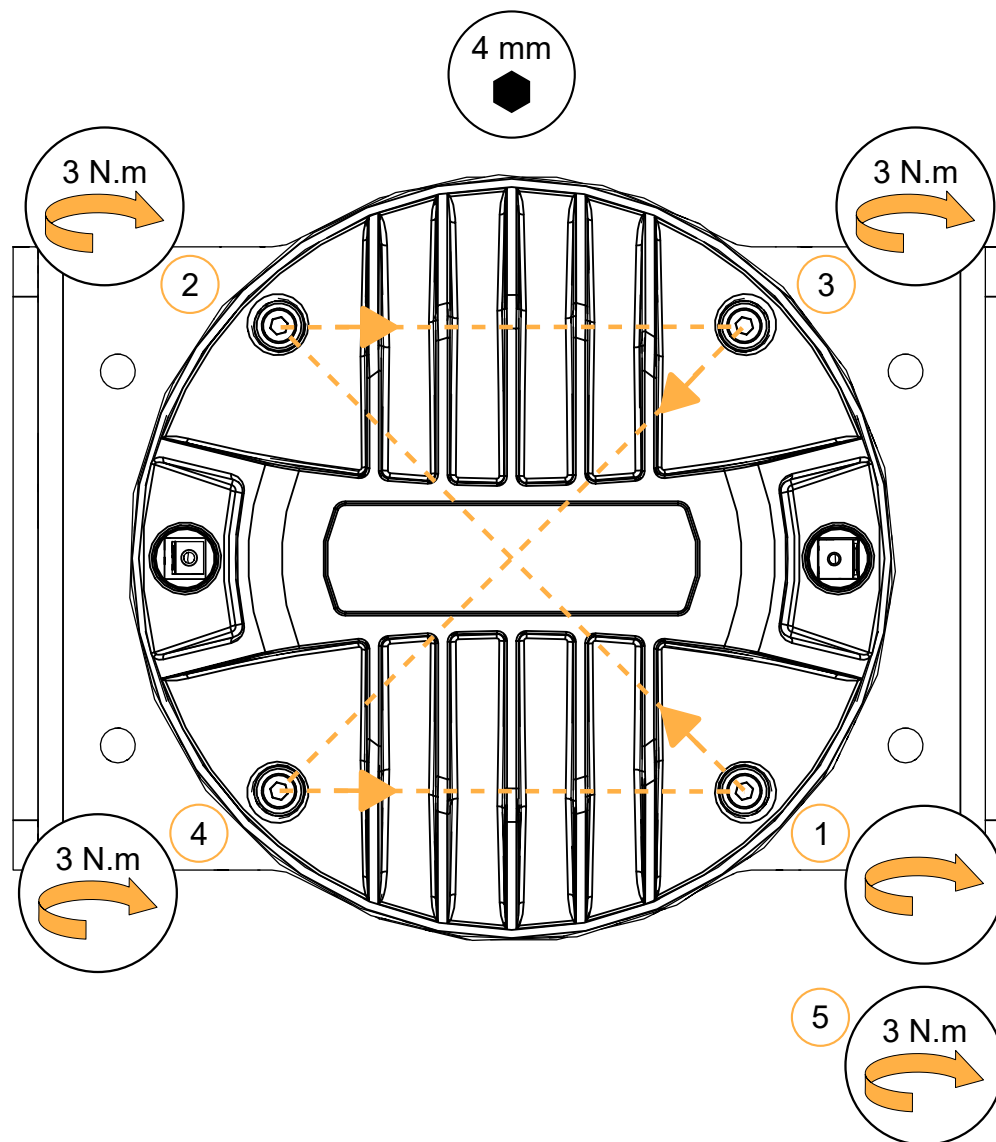

What to do next

Perform the [Acoustical check](#) (p.42) procedures.

Specifications

K3i specifications

Description	2-way active WST® enclosure: 2 x 12" LF + 4" HF diaphragm (installation version), amplified by LA4X / LA8 / LA12X
Usable bandwidth (-10 dB)	42 Hz - 20 kHz ([K3 70])
Maximum SPL¹	143 dB ([K3 70])
Nominal directivity (-6 dB)	horizontal: 70° / 110° symmetric or 90° asymmetric vertical: depending on number of elements and array curvature
Transducers	LF: 2 x 12" neodymium cone driver HF: 1 x 4" neodymium diaphragm compression driver
Acoustical load	LF: bass-reflex, L-Vents HF: DOOSC waveguide, L-Fins
Nominal impedance	LF: 8 Ω HF: 8 Ω
Connectors	IN: 1 x 4-point terminal block with push-in connection LINK: 1 x 4-point terminal block with push-in connection
Rigging and handling	external rigging kits M8 inserts for rigging plates M6 inserts for K3i-SCREEN inter-element angles: 0.25°, 1°, 2°, 3°, 4°, 5°, 7.5° or 10°
Weight (net)	36 kg / 78 lb
Cabinet	premium grade Baltic birch plywood
Front	coated steel grill acoustically neutral 3D fabric
Finish	dark grey brown Pantone 426 C pure white RAL 9010 custom RAL code on special order
IP	IP55

¹ Peak level measured at 1 m under free field conditions using pink noise with crest factor 4 (preset specified in brackets).

K3i dimensions

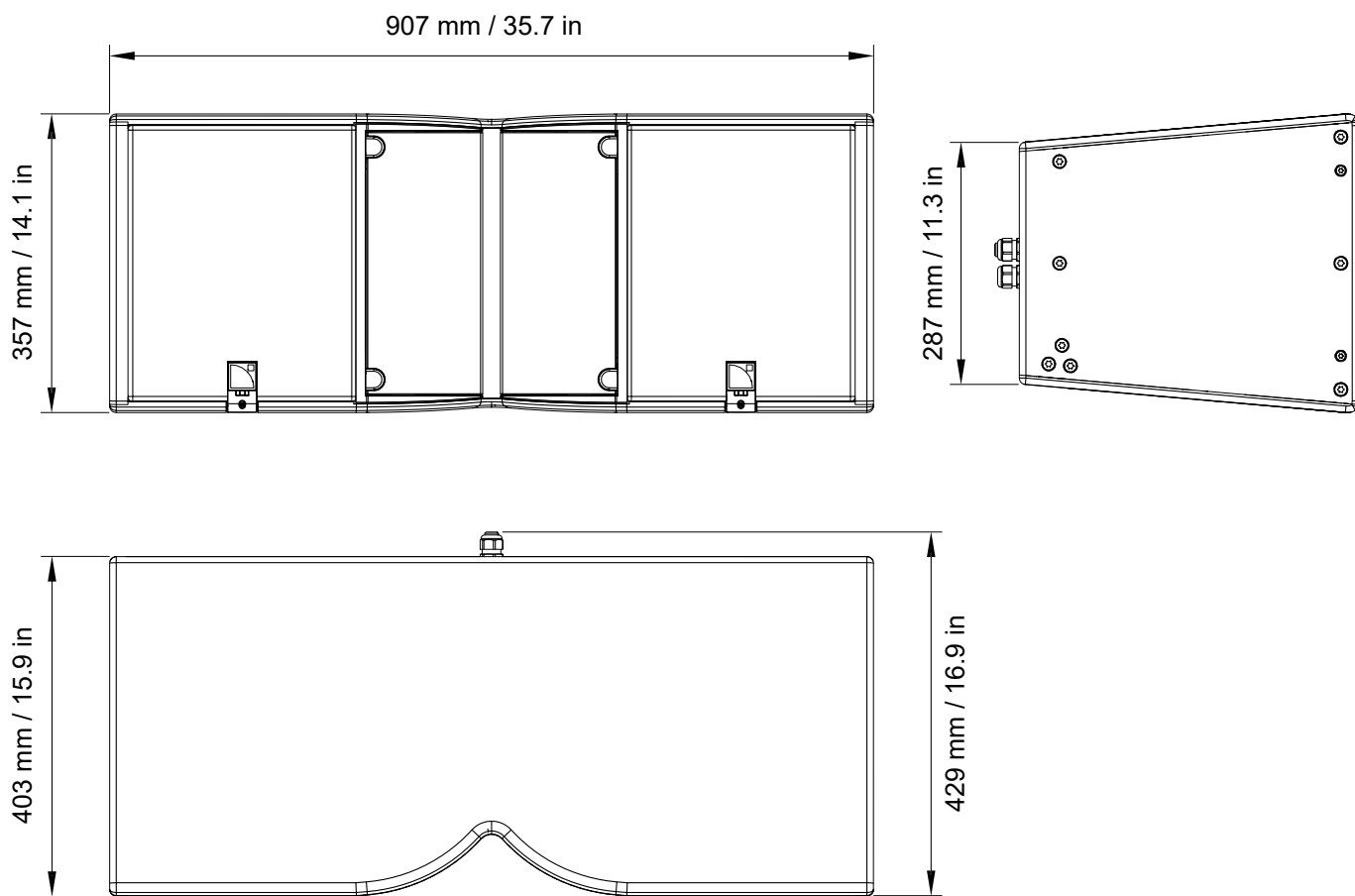

Kara Ili specifications

Description	2-way active WST® enclosure: 2 × 8" LF + 3" HF diaphragm (installation version), amplified by LA2Xi / LA4X / LA8 / LA12X
Usable bandwidth (-10 dB)	55 Hz - 20 kHz ([KARA II 70])
Maximum SPL¹	142 dB ([KARA II 70]) with LA4X / LA8 / LA12X 137 dB ([KARA II 70]) with LA2Xi
Nominal directivity (-6 dB)	horizontal: 70° / 110° symmetric or 90° asymmetric (35°/90°) vertical: dependent upon the number of elements and the line source curvature
Transducers	LF: 2 × 8" neodymium cone drivers HF: 1 × 3" neodymium diaphragm compression driver
Acoustical load	LF: bass-reflex HF: DOOSC waveguide, L-Fins
Nominal impedance	LF: 8 Ω HF: 8 Ω
Connectors	IN: 1 × 4-point terminal block with push-in connection LINK: 1 × 4-point terminal block with push-in connection
Rigging and handling	external rigging kits 10 M6 inserts for rigging 4 M6 inserts for screens inter-element angles: 0°, 1°, 2°, 3°, 4°, 5°, 7.5° or 10°
Weight (net)	21 kg / 46 lb
Cabinet	premium grade Baltic birch plywood
Front	coated steel grill acoustically neutral 3D fabric
Finish	dark grey brown Pantone 426 C pure white RAL 9010 custom RAL code on special order
IP	IP55

¹ Peak level measured at 1 m under free field conditions using pink noise with crest factor 4 (preset specified in brackets).

Kara Ili dimensions

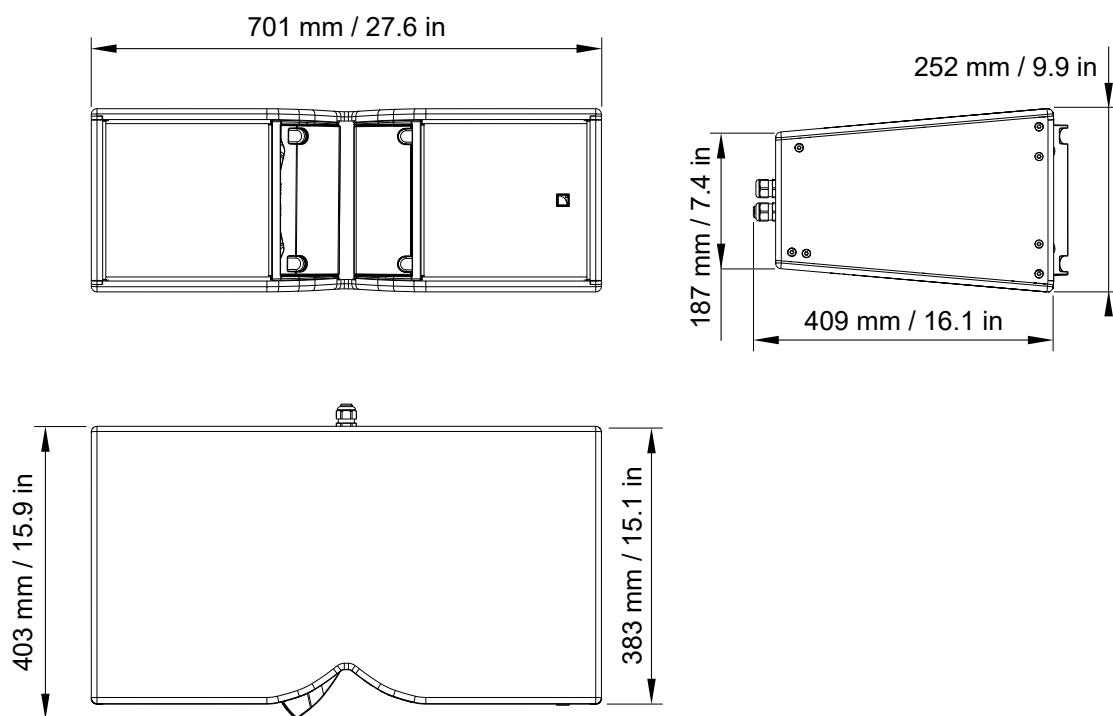

KS28 specifications

Description	Flyable subwoofer 2 x 18" , amplified by LA12X
Low frequency limit (-10 dB)	25 Hz ([KS28_100])
Maximum SPL¹	143 dB ([KS28_100])
Directivity	standard or cardioid
Transducers	2 x 18" neodymium cone drivers
Acoustical load	bass-reflex, L-Vents
Nominal impedance	4 Ω
Connectors	IN: 1 x 4-point speakON
Rigging and handling	flush-fitting 2-point rigging system 6 ergonomic handles 2 ground runners 8 side runners
Weight (net)	79 kg / 174 lb
Cabinet	premium grade Baltic beech and birch plywood
Front	coated steel grill acoustically neutral 3D fabric
Rigging components	high grade steel
Finish	dark grey brown Pantone 426 C

¹ Peak level at 1 m under half space conditions using pink noise with crest factor 4 (preset specified in brackets).

KS28 dimensions

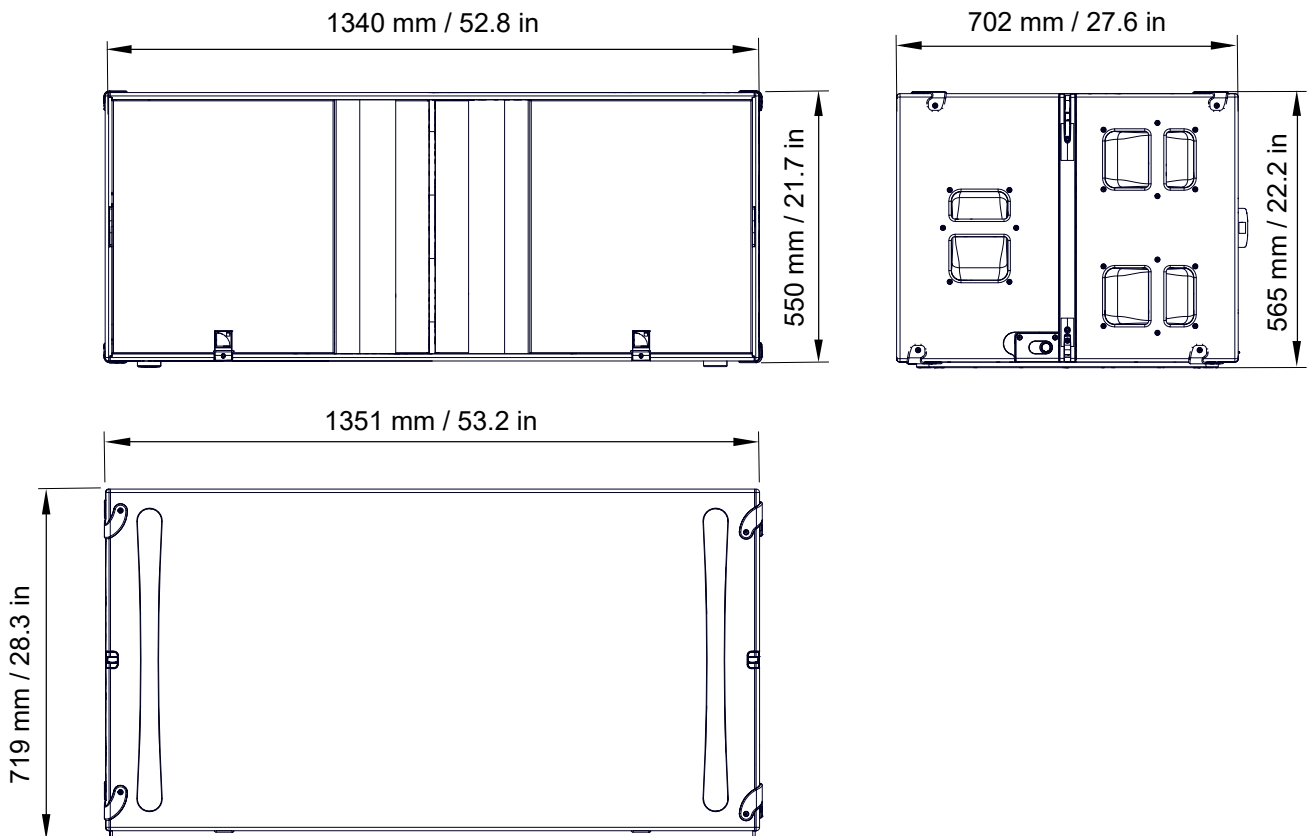

KS21i specifications

Description	High power compact subwoofer: 1 x 21" (installation version), amplified by LA2Xi / LA4X / LA8 / LA12X
Low frequency limit (-10 dB)	31 Hz ([KS21_100])
Maximum SPL ¹	138 dB ([KS21_100]) with LA2Xi (bridge mode) / LA4X / LA8 / LA12X 131 dB ([KS21_100]) with LA2Xi
Nominal directivity (-6 dB)	standard or cardioid configuration
Transducers	1 x 21" neodymium cone driver
Acoustical load	bass-reflex, L-Vents
Nominal impedance	8 Ω
Connectors	1 x 4-point terminal block with push-in connection
Rigging and handling	external rigging kits M6 inserts for rigging plates M8 inserts for A-U15i 1 DIN580-compatible M8 threaded insert
Weight (net)	46 kg / 101 lb
Cabinet	premium grade Baltic beech and birch plywood
Front	coated steel grill acoustically neutral 3D fabric
Finish	dark grey brown Pantone 426 C pure white RAL 9010 custom RAL code on special order
IP	IP55

¹ Peak level at 1 m under half space conditions using pink noise with crest factor 4 (preset specified in brackets).

KS21i dimensions

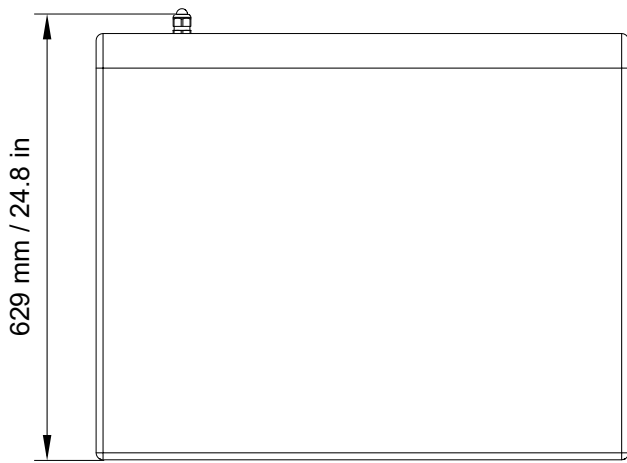
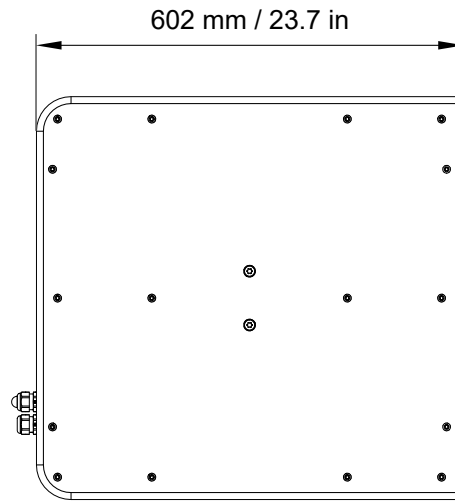
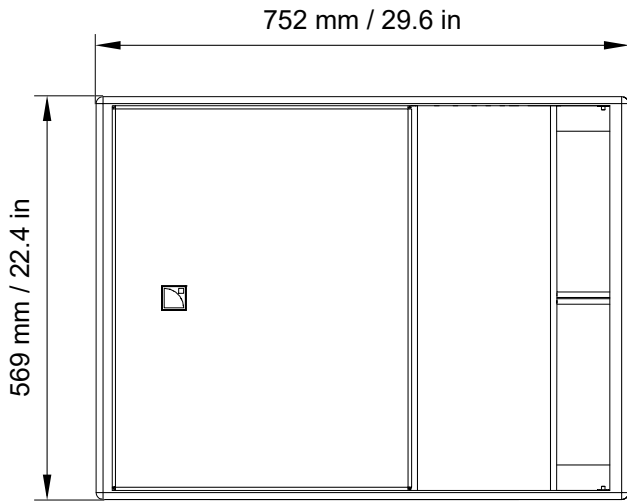

K3i-BUMP specifications

Description	Flying frame for K3i 2 Ø19 mm shackles WLL 3.25 t
Weight (net)	21 kg / 45 lb
Material	high grade steel with anti-corrosion coating

K3i-BUMP dimensions

913 mm / 35.9 in

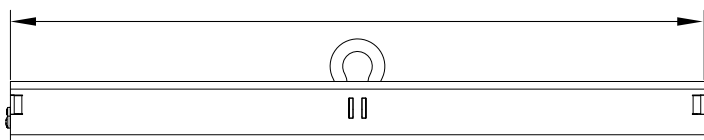

80 mm / 3.1 in

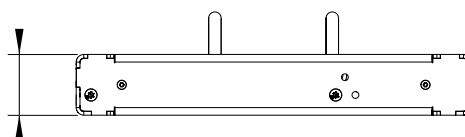

520 mm / 20.5 in

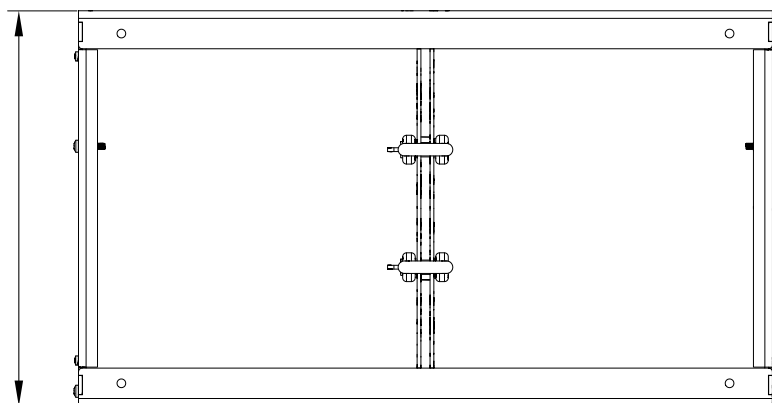

K3i-RIGBAR specifications

Description	Rigging bar and pullback for K3i 2 Ø12 mm shackles WLL 1 t
Weight (net)	9.3 kg / 20 lb
Material	high grade steel with anti-corrosion coating

K3i-RIGBAR dimensions

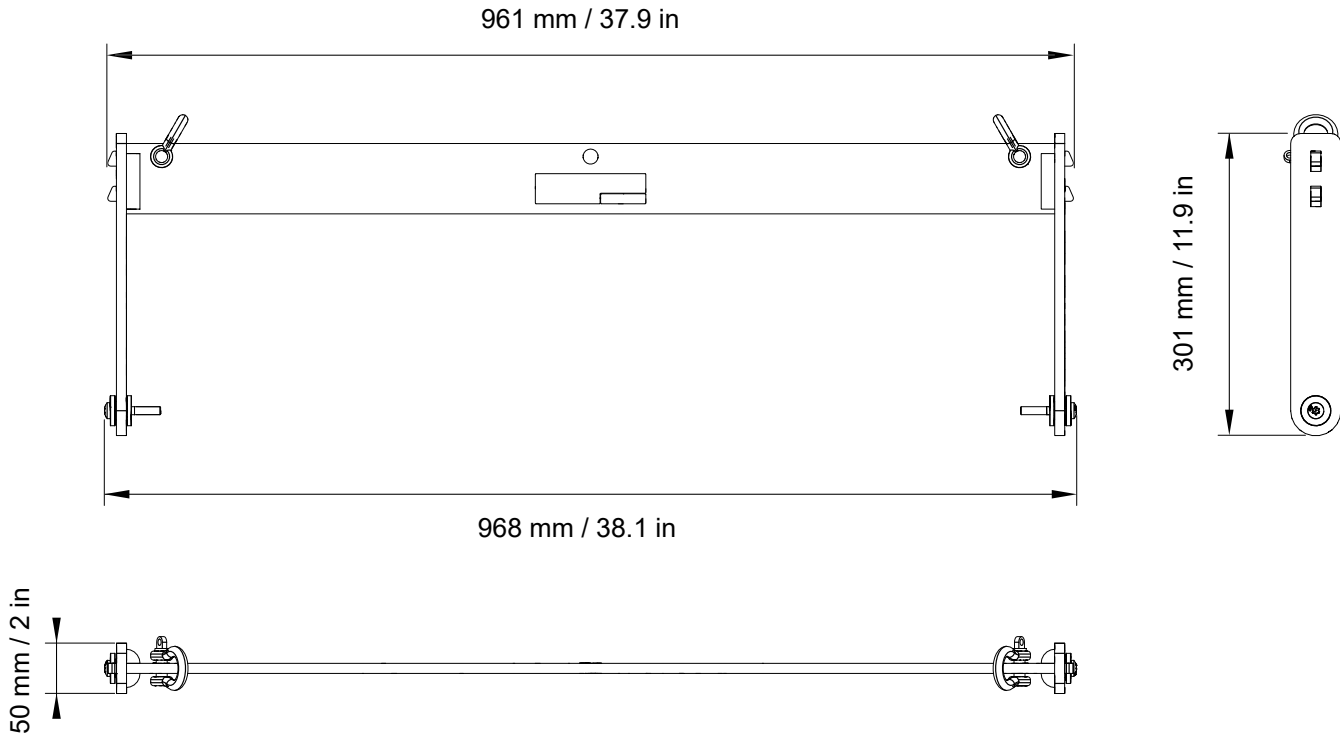

K3i-BAR specifications

Description	Extension bar for K3i-BUMP 2 Ø19 mm shackles WLL 3.25 t 2 Ø25 mm axis, M12 nuts, and safety pins
Weight (net)	17 kg / 36 lb
Material	high grade steel with anti-corrosion coating

K3i-BAR dimensions

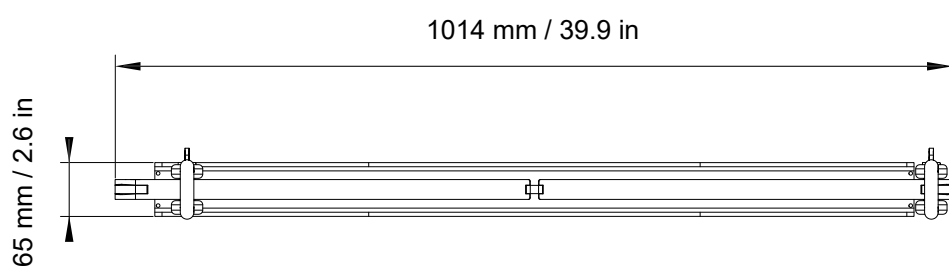
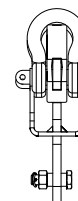
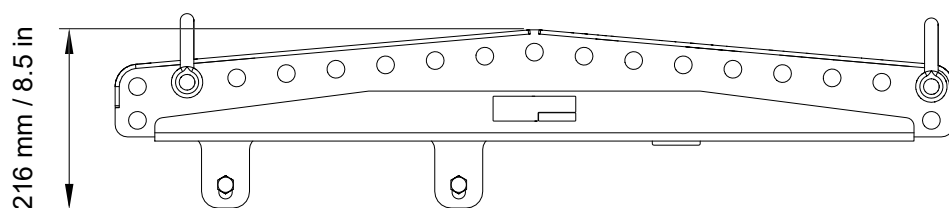

KARAIi-DOWNK3i specifications

Description	Interface for flying Kara Ili below K3i
Weight (net)	10 kg / 22 lb
Material	high grade steel with anti-corrosion coating

KARAIi-DOWNK3i dimensions

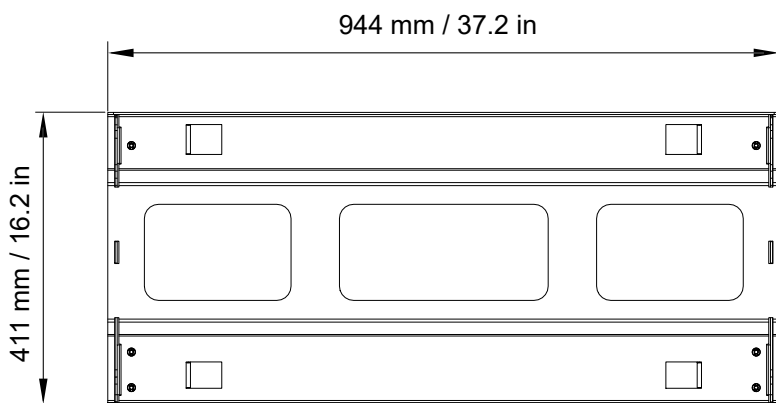
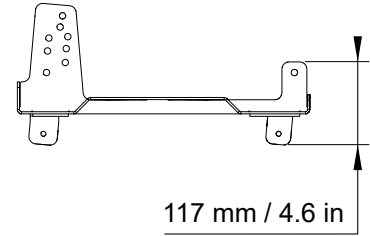
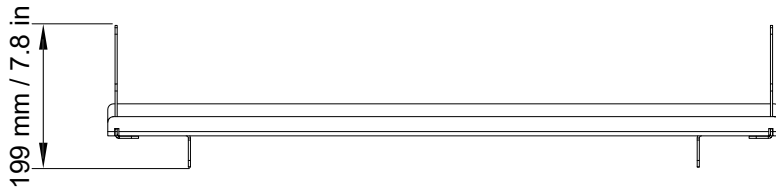

K3i-TILTBRACKET specifications

Description	Fastening bracket with angles for K3i
Weight (net)	1.3 kg / 2.2 lb
Material	high grade steel with anti-corrosion coating

K3i-TILTBRACKET dimensions

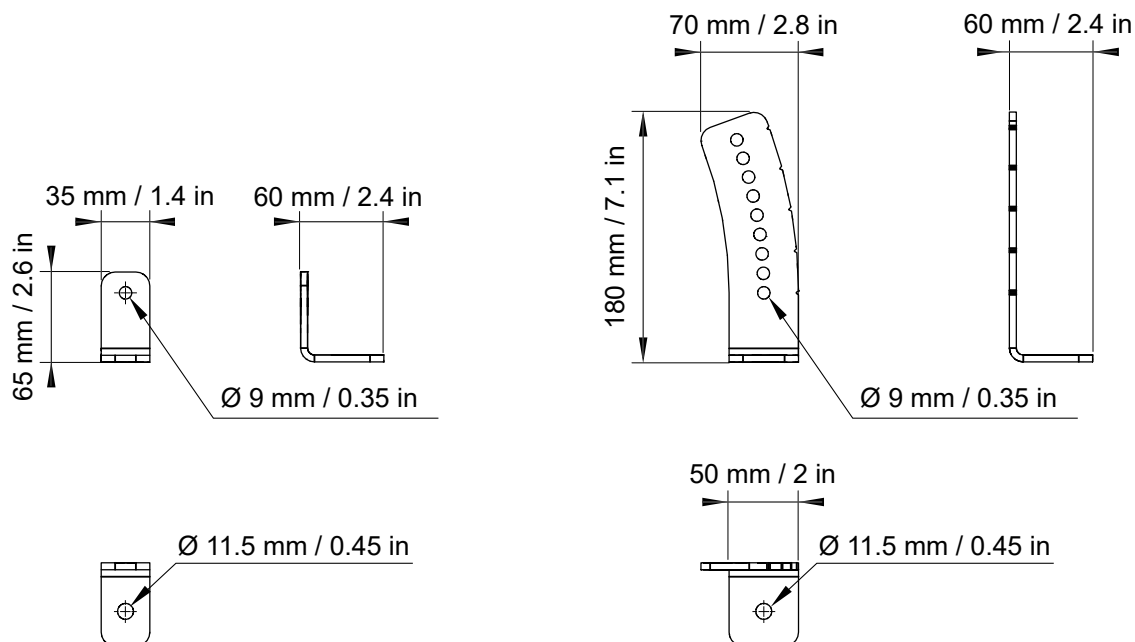

K3i-CEILINGBRACKET specifications

Description	Ceiling fastening bracket with angles for K3i
Weight (net)	1 kg / 2.2 lb
Material	high grade steel with anti-corrosion coating

K3i-CEILINGBRACKET dimensions

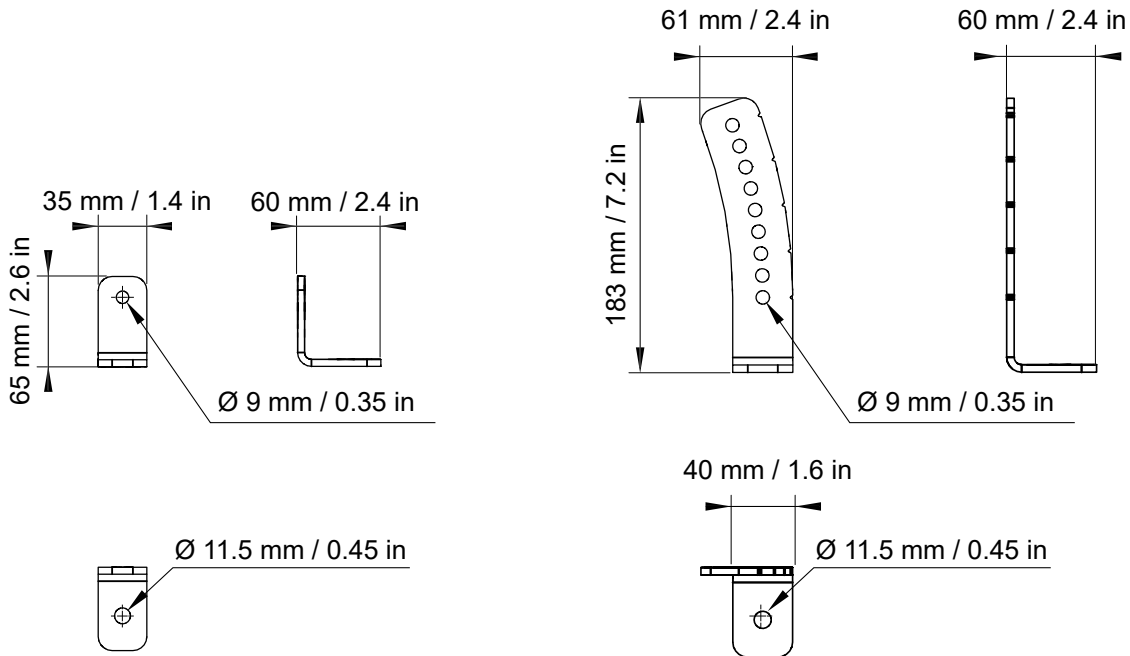

K3i-SCREEN specifications

Description	Acoustically transparent front screen for K3i
Weight (net)	2.4 kg / 4.4 lb
Material	high grade steel with anti-corrosion coating

K3i-SCREEN dimensions

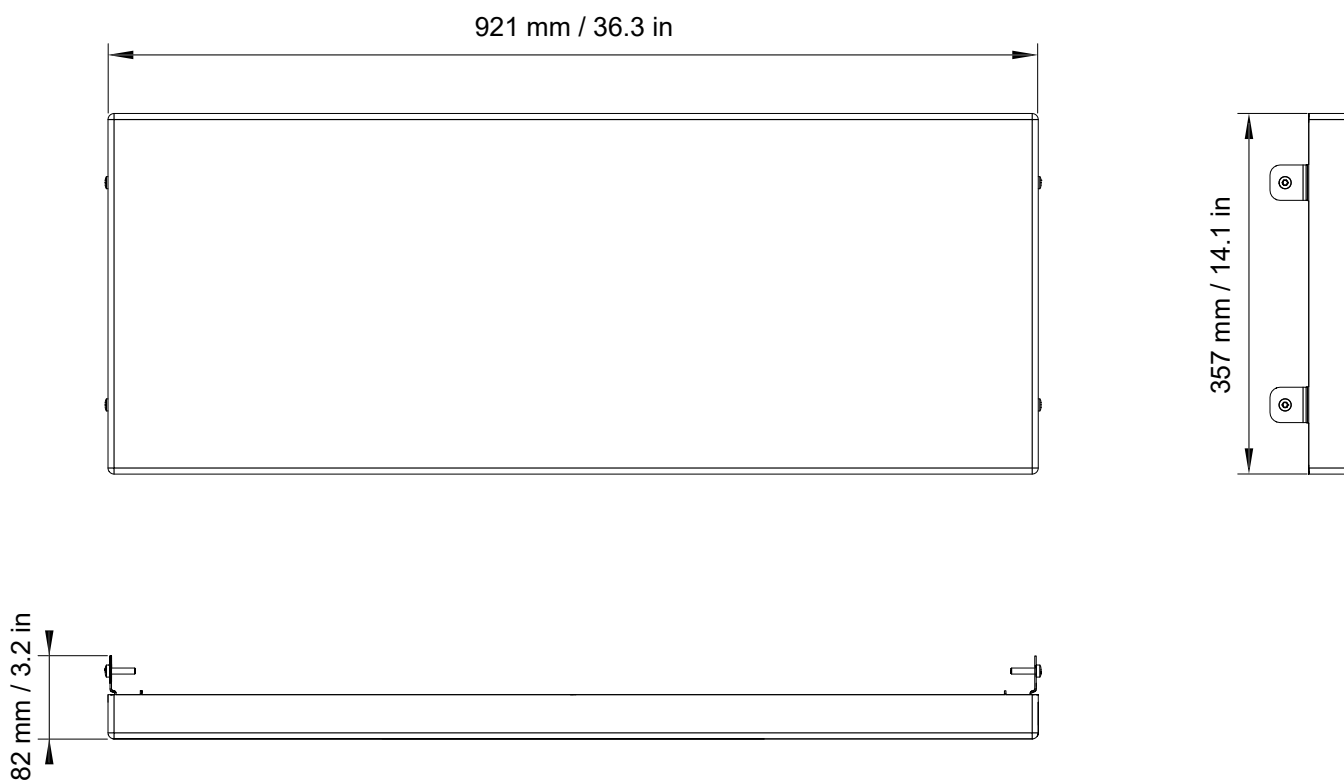

CLAMP250 specifications

Description	Clamp certified for 250 kg
Weight (net)	1.8 kg / 4 lb
Material	high grade steel with anti-corrosion coating

CLAMP250 dimensions

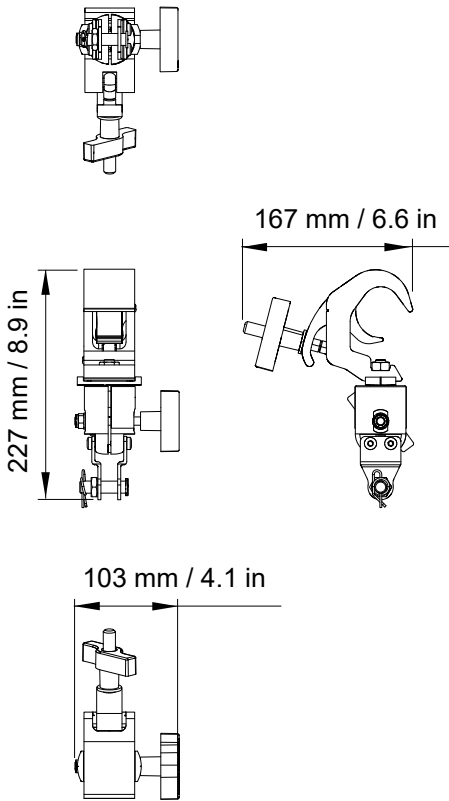

Recommendation for speaker cables

Follow the recommended maximum length for loudspeaker cables to ensure minimal SPL attenuation.



Cable quality and resistance

Only use high-quality fully insulated speaker cables made of stranded copper wire.

Use cables with a gauge offering low resistance per unit length and keep the cables as short as possible.

The table below provides the recommended maximum length for loudspeaker cables depending on the cable gauge and on the impedance load connected to the amplifier.

cable gauge			recommended maximum length					
			8 Ω load		4 Ω load		2.7 Ω load	
mm ²	SWG	AWG	m	ft	m	ft	m	ft
2.5	15	13	30	100	15	50	10	33
4	13	11	50	160	25	80	17	53
6	11	9	74	240	37	120	25	80

Use the more detailed L-Acoustics calculation tool to evaluate cable length and gauge based on the type and number of enclosures connected. The calculation tool is available on our website:

<https://www.l-acoustics.com/installation-tools/>

Specifications for custom rigging systems

Dimensions

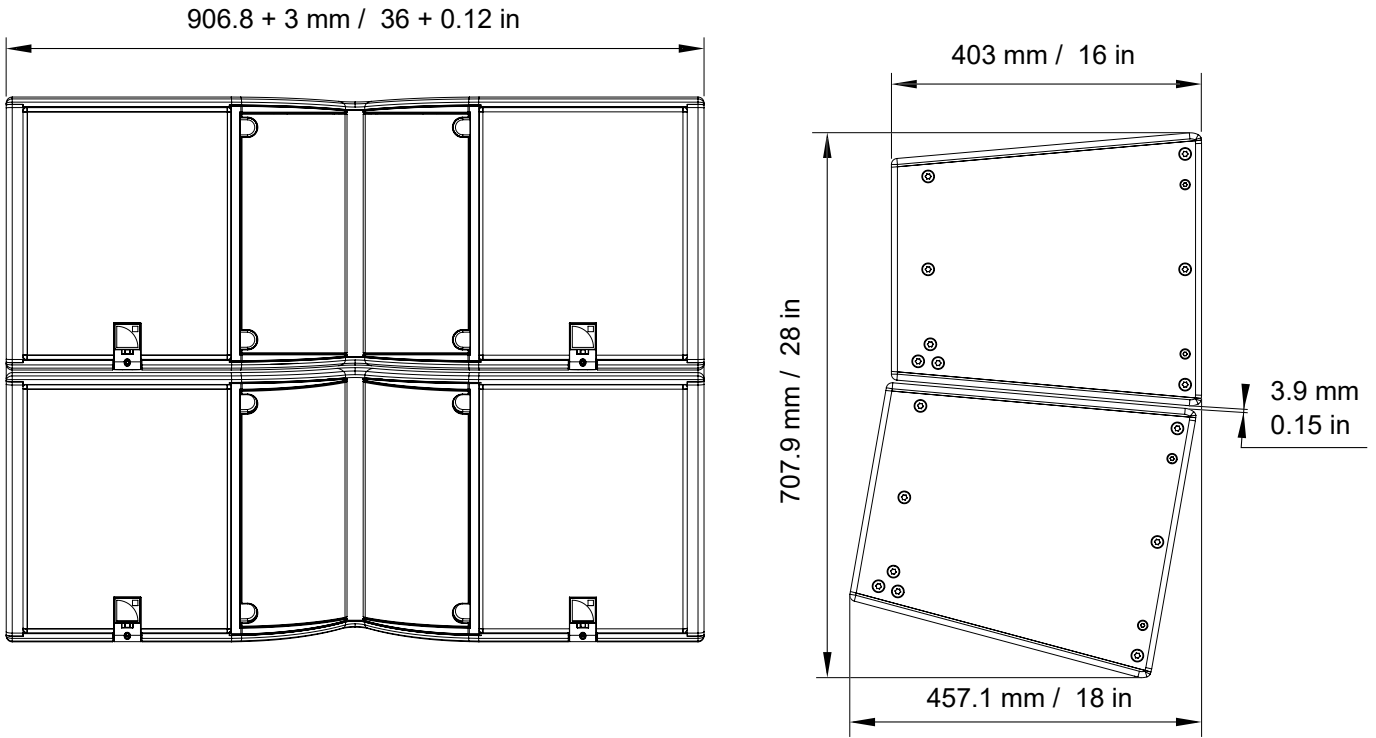

Center of gravity

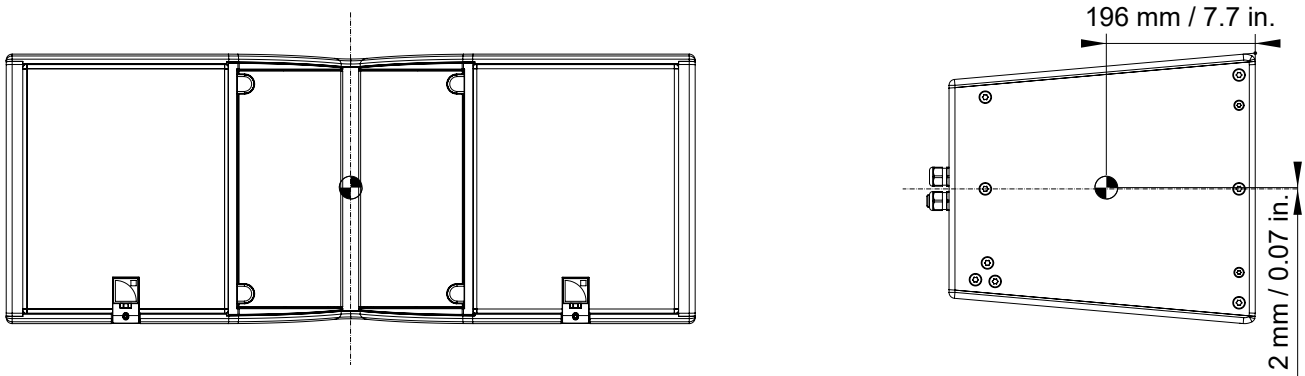

Threaded inserts and screws



Use only rigging inserts to implement a custom rigging

Inserts marked with  can be used for rigging.

Inserts marked with  must not be used for custom rigging (reserved for screen mounting, maintenance purposes, L-Acoustics accessories, etc.).



Grade of screws must be defined by a qualified person

Take into consideration the number of inserts used, weight and center of gravity of enclosure(s), and resulting action forces.

Prevent screws from loosening (threadlocker, spring washer...).

K3i has **8 threaded M8 inserts** available for custom rigging.

	M8 inserts
Ultimate Tensile Strength	1160 N
Ultimate Shear Strength	5700 N
Recommended screws length*	min 35 mm / 1.4 in.
Recommended torque	7 N.m



* Recommended screw length for a metal sheet with a thickness of 3 mm / 0.1 in. Adapt the length to the custom rigging design.

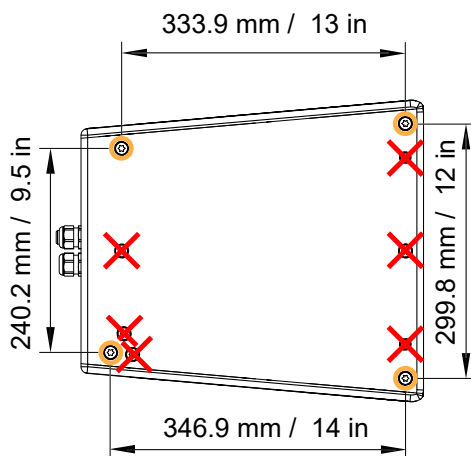



L-Acoustics

13 rue Levacher Cintrat - 91460 Marcoussis - France
+33 1 69 63 69 63 - info@l-acoustics.com
www.l-acoustics.com

 **L-ACOUSTICS**
GROUP