

Introduction

This document is intended for all users of L-Acoustics products. It gathers reference information about connecting enclosures to amplified controllers.

- Refer to [Impedance load and output power](#) (p.1) to identify the nominal impedance of an enclosure and calculate the **total impedance**, and identify the amplified controller **maximum output power**.
- Refer to [Enclosure drive capacity per amplified controller](#) (p.2) to identify **the type and quantity of enclosures** that can be driven by each amplified controller.
- Refer to [Enclosure maximum SPL per amplified controller](#) (p.4) to identify the **maximum SPL** delivered by an enclosure, depending on the preset and the amplified controller.
- [Loudspeaker connection](#) (p.5) contains **generic cabling schemes** with L-Acoustics speaker cables, categorized by type of enclosure.
- To prepare cables for a **fixed installation project**, refer to [Recommendation for speaker cables](#) (p.10).



For more information about enclosure presets and delay settings, refer to the **Preset Guide**.

Impedance load and output power

Most enclosures have a nominal impedance of 8 Ω. The exceptions are:

- 16 Ω:
 - K2 (HF section), Kiva II, V-DOSC (HF section), 5XT, X4i
- 4 Ω:
 - SB28, KS28, Syva Low, K1-SB, SB6i

total impedance

Nominal	number of enclosures/sections in parallel				
	2	3	4	5	6
16 Ω	8 Ω	5.3 Ω	4 Ω	3.2 Ω	2.7 Ω
8 Ω	4 Ω	2.7 Ω	—	—	—



4 Ω enclosures cannot be connected in parallel.*

Refer to [Enclosure drive capacity per amplified controller](#) (p.2) for the maximum number of enclosures/sections per output and in total on each amplified controller.

* with the exception of Syva Low and SB6i

amplified controllers maximum output power

Type		16 Ω load	8 Ω load	4 Ω load	2.7 Ω load
LA12X		4 × 700 W	4 × 1400 W	4 × 2600 W	4 × 3300 W
LA7.16(i)		16 × 580 W	16 × 920 W	16 × 1000 W	—
LA4X		4 × 500 W	4 × 1000 W		—
LA2Xi	SE	4 × 190 W	4 × 360 W	4 × 640 W	—
	BTL	2 × 710 W	2 × 1260 W	—	
	PBTL	—	—	1 × 2550 W	
LA1.16i	SE	16 × 40 W	16 × 80 W	16 × 120 W	—
	BTL	8 × 160 W	8 × 230 W	—	

CEA-2006/490A 1 kHz test method, all channels driven.

Enclosure drive capacity per amplified controller**Risks of output mute, global attenuation, or loss of audio quality.**

Do not exceed the maximum number of connected enclosures per channel and in total.

Driving more enclosures than indicated can trigger the amplified controller protection systems.

For L-SMART compatible amplified controllers (LA1.16i and LA7.16(i)), values are given for nominal use, assuming that all channels are driven at full power. When sending the same signal to all outputs, never exceed the maximum numbers, regardless of the Power Budget values, otherwise the Fuse Protect algorithm may be triggered. For LA7.16(i), when powered by a 100 V power supply, reduce the number of enclosures in order not to exceed 75% of the power gauge.

For LA1.16i, the maximum number of connected enclosures in total may differ depending on the preset. Refer to Soundvision and LA Network Manager for Power Budget monitoring.

	LA1.16i		LA2Xi			LA4X	LA7.16(i)	LA12X
	per output* / total		per output* / total			per output* / total	per output* / total	per output* / total
	SE	BTL	SE	BTL	PBTL			
X4i	3 / 48	2 / 12	4 / 16	—		4 / 16	4 / 64	6 / 24
5XT	3 / 48	2 / 14	4 / 16	—		4 / 16	3 / 48	6 / 24
X6i	2 / 20	1 / 8	2 / 8	1 / 2	—	2 / 8	1 / 16	3 / 12
X8	2 / 32	1 / 8	2 / 8	1 / 2	—	2 / 8	1 / 16	3 / 12
X8i	2 / 30	1 / 8	2 / 8	1 / 2	—	2 / 8	1 / 16	3 / 12
X12	—	1 / 4	1 / 4	1 / 2	—	1 / 4	1 / 14	3 / 12
X15 HiQ	—		1 / 2	—		1 / 2	1 / 8	3 / 6
Soka	2 / 26	1 / 4	1 / 4	1 / 2	—	2 / 8	1 / 16	3 / 12
Syva	—		1 / 4	1 / 2	—	1 / 4	1 / 10	3 / 12
A10(i) Wide/Focus	—	1 / 4	2 / 8	1 / 2	—	2 / 8	1 / 16	3 / 12
A15(i) Wide/Focus	—		1 / 4	1 / 2	—	1 / 4	1 / 10	3 / 12
K1	—		—			—	—	2 / 2
K1-SB	—		—			—	—	1 / 4

	LA1.16i		LA2Xi			LA4X	LA7.16(i)	LA12X
	per output* / total		per output* / total			per output* / total	per output* / total	per output* / total
	SE	BTL	SE	BTL	PBTL			
K2	—		—			1 / 1	1 / 4	3 / 3
K3(i)	—		—			1 / 2	1 / 8	3 / 6
Kara II(i)	—		2 / 4	—		2 / 4	1 / 8	3 / 6
Kiva II	—	2 / 10	2 / 8	2 / 4	—	2 / 8	2 / 32	6 / 24
L2 / L2D	—		—			—	1 / 1	—
CS1	—		—			—	1 / 2	2 / 2
KS28	—		1 / 4	—	1 / 1	—	—	1 / 4
KS21(i)	—		1 / 4	1 / 2	—	1 / 4	1 / 8	2 / 8
SB18 / SB18 Ili	—		1 / 4	1 / 2	—	1 / 4	1 / 6	3 / 12
SB15m	—		1 / 4	1 / 2	—	1 / 4	1 / 9	3 / 12
Syva Low	—		1 / 4	—		1 / 4	1 / 8	2 / 6 ^a
Syva Sub	—	1 / 4	1 / 4	1 / 2	—	1 / 4	1 / 16	3 / 12
SB10i	2 / 20	1 / 4	2 / 8	1 / 2	—	2 / 8	2 / 32	3 / 12
SB6i	1 / 12	—	1 / 4	—		1 / 4	1 / 16	2 / 8

For discontinued loudspeaker enclosures and amplified controllers, refer to the Preset Guide.

* For passive loudspeakers, the value corresponds to the number of enclosures in parallel on the output. For active loudspeakers, the value corresponds to the number of sections in parallel on the output.

^a LA12X can drive up to two Syva Low per output, but no more than six per controller at high level.

Enclosure maximum SPL per amplified controller

Peak level measured at 1 m, under free field conditions for full range loudspeakers and half space conditions for subwoofers, using pink noise with crest factor 4.

product	preset	LA1.16i		LA2Xi			LA4X	LA7.16(i)	LA12X
		SE	BTL	SE	BTL	PBTL			
X4i	[X4]	107 dB	115 dB	116 dB	—	—	116 dB		
	[X4_60]	104 dB	110 dB	110 dB	—	—	110 dB		
5XT	[5XT]	112 dB	120 dB	121 dB	—	—	121 dB		
X6i	[X6i_50]	110 dB	117 dB	117 dB	—	—	117 dB		
	[X6i]	115 dB	122 dB	122 dB	123 dB	—	123 dB		
X8	[X8]	117 dB	124 dB	125 dB	129 dB	—	129 dB		
X8i	[X8i_40]	114 dB	121 dB	121 dB	123 dB	—	123 dB		
	[X8i]	117 dB	124 dB	125 dB	129 dB	—	129 dB		
X12	[X12]	—	131 dB	131 dB	136 dB	—	136 dB		
X15 HiQ	[X15]	—	—	133 dB	—	—	138 dB		
Soka	[SOKA]	119 dB	127 dB	128 dB	130 dB	—	130 dB		
	[SOKA_60]	114 dB	122 dB	124 dB	124 dB	—	124 dB		
	[SOKA_200]	120 dB	130 dB	130 dB	133 dB	—	133 dB		
Syva	[SYVA]	—	—	130 dB	137 dB	—	137 dB		
A10(i) Wide	[A10] (70°)	—	132 dB	133 dB	137 dB	—	137 dB		
A10(i) Focus	[A10] (70°)	—	135 dB	136 dB	140 dB	—	140 dB		
A15(i) Wide	[A15] (70°)	—	—	136 dB	141 dB	—	141 dB		
A15(i) Focus	[A15] (70°)	—	—	139 dB	144 dB	—	144 dB		
K1	[K1]	—	—	—	—	—	—	—	149 dB
K1-SB	[K1SB_60]	—	—	—	—	—	—	—	141 dB
	[K1SB_100_NC]	—	—	—	—	—	—	—	142 dB
	[K1SB_X]	—	—	—	—	—	—	—	145 dB
K2	[K2 70]	—	—	—	—	—	147 dB		
K3(i)	[K3 70]	—	—	—	—	—	143 dB		
Kara II(i)	[KARA II 70]	—	—	137 dB	—	—	142 dB		
Kiva II	[KIVA II]	—	132 dB	133 dB	138 dB	—	138 dB		
L2	[L2 70]	—	—	—	—	—	—	155 dB (entire enclosure)	—
L2D	[L2D 70]	—	—	—	—	—	—	151 dB (entire enclosure)	—
CS1	[CS1_60]	—	—	—	—	—	—	147 dB	
	[CS1_X]	—	—	—	—	—	—	150 dB	—
KS28	[KS28_100]	—	—	136 dB	—	143 dB	—	—	143 dB

product	preset	LA1.16i		LA2Xi			LA4X	LA7.16(i)	LA12X
		SE	BTL	SE	BTL	PBTL			
KS21(i)	[KS21_100]	—	—	131 dB	138 dB	—	138 dB		
SB18 (Ili)	[SB18_100]	—	—	133 dB	138 dB	—	138 dB		
SB15m	[SB15_100]	—	—	131 dB	137 dB	—	137 dB		
Syva Low	[SYVA LOW_100]	—	—	131 dB	—	—	137 dB		
Syva Sub	[SYVA SUB_60]	—	119 dB	122 dB	—	—	122 dB		
	[SYVA SUB_100]	—	122 dB	123 dB	128 dB	—	128 dB		
	[SYVA SUB_200]	—	123 dB	125 dB	130 dB	—	130 dB		
SB10i	[SB10_60]	111 dB	118 dB	119 dB	—	—	119 dB		
	[SB10_100]	112 dB	120 dB	120 dB	122 dB	—	122 dB		
	[SB10_200]	114 dB	123 dB	123 dB	125 dB	—	125 dB		
SB6i	[SB6_60]	106 dB	—	110 dB	—	—	110 dB		
	[SB6_100]	106 dB	—	111 dB	—	—	111 dB		
	[SB6_200]	108 dB	—	115 dB	—	—	115 dB		

Loudspeaker connection



For specific cabling instructions, refer to the user documentation of the enclosure system.

1-channel enclosures

1-channel speakON output

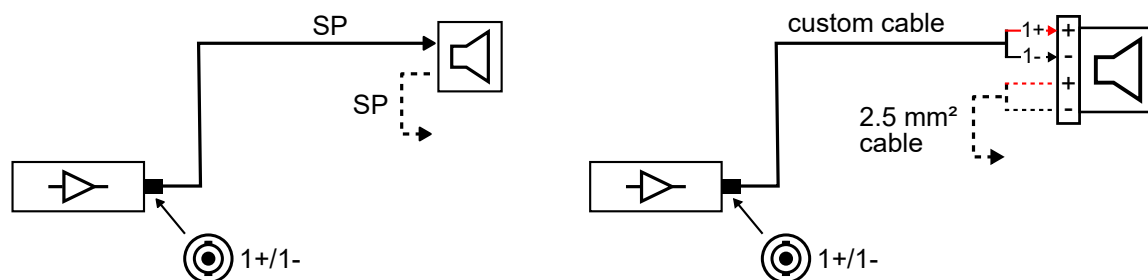

2-channel speakON output

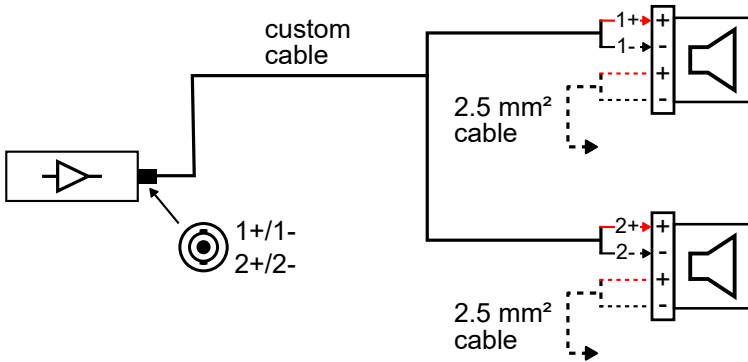
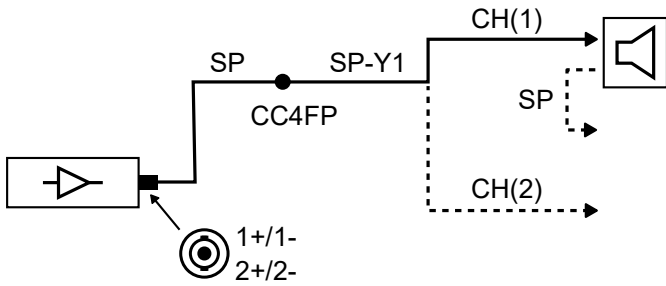

4-channel CA-COM output

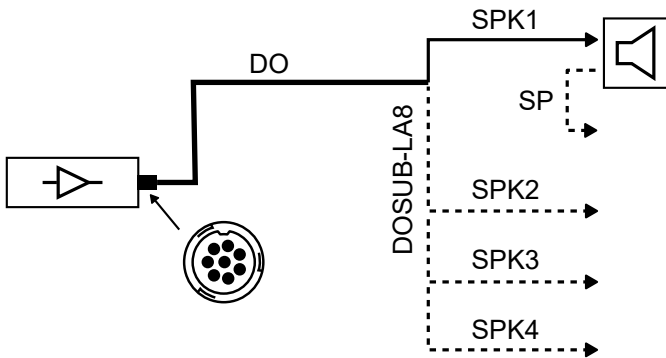

LA1.16i / LA2Xi / LA7.16i terminal block output (SE)

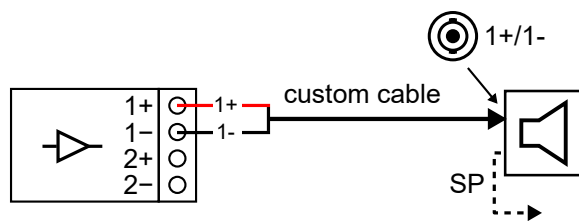
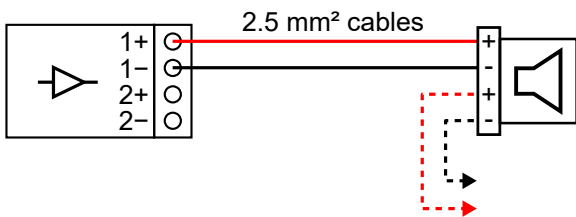

LA1.16i / LA2Xi terminal block output (BTL)

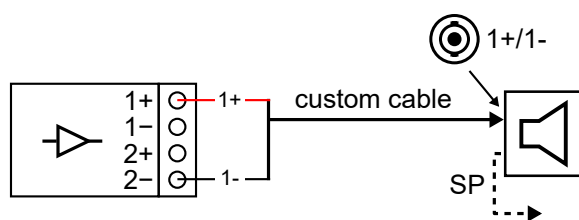
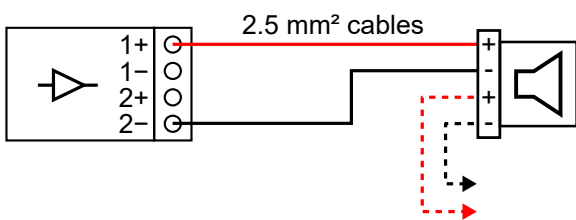

LA2Xi terminal block output (PBTL)

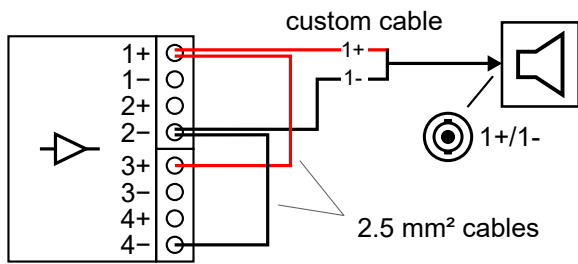

2-channel enclosures

2-channel speakON output

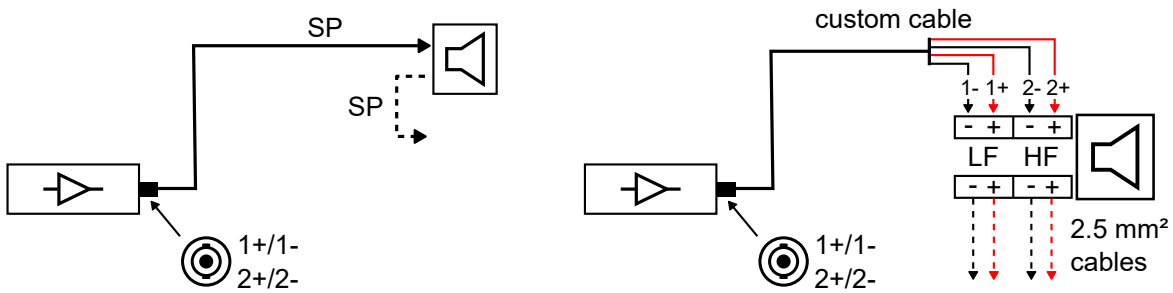

4-channel CA-COM output

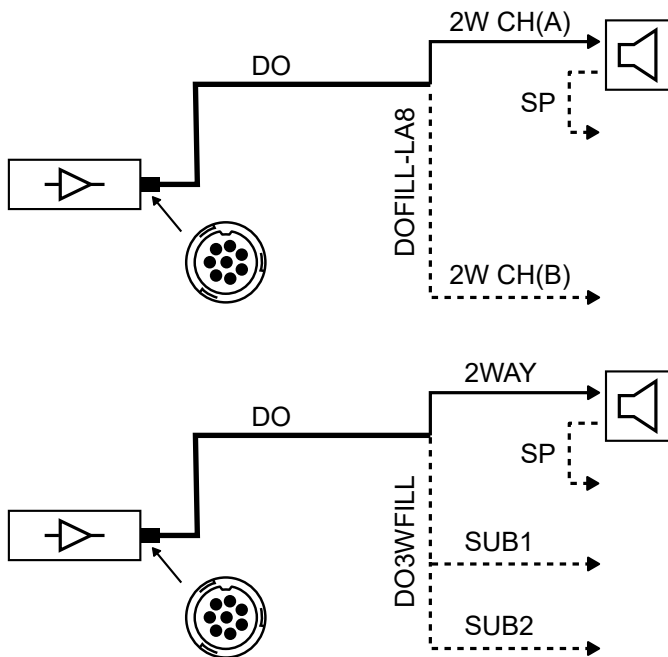

LA2Xi / LA7.16i terminal block output (SE)

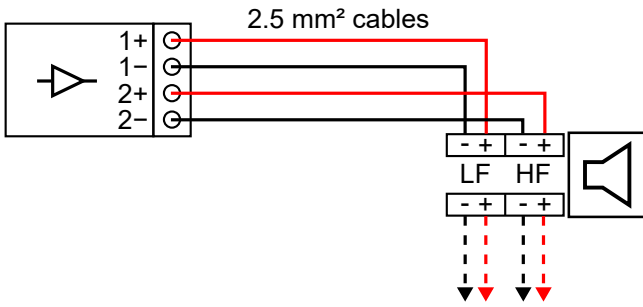

4-channel enclosures

4-channel CA-COM output

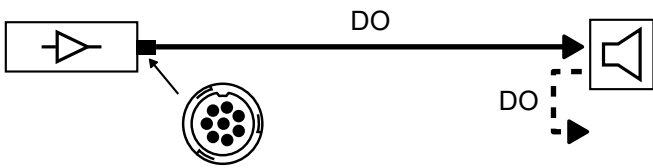

LA7.16i terminal block output

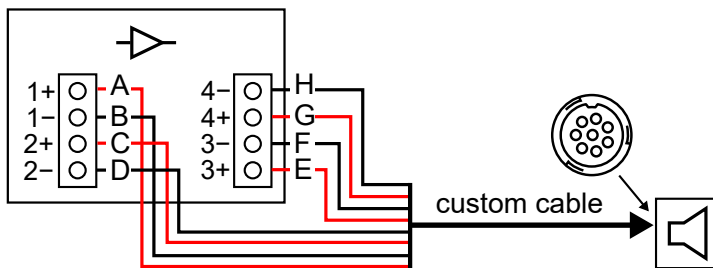

4-channel SC32 output

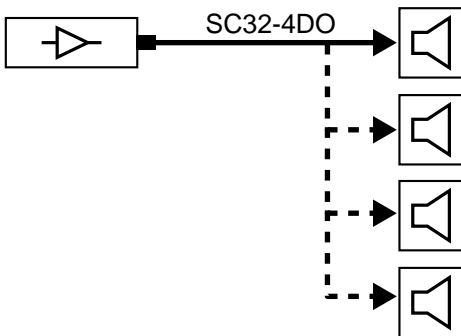

16-channel enclosures

16-channel connector output

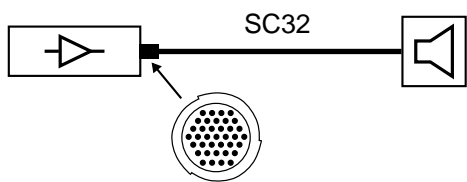

LA7.16i terminal block output

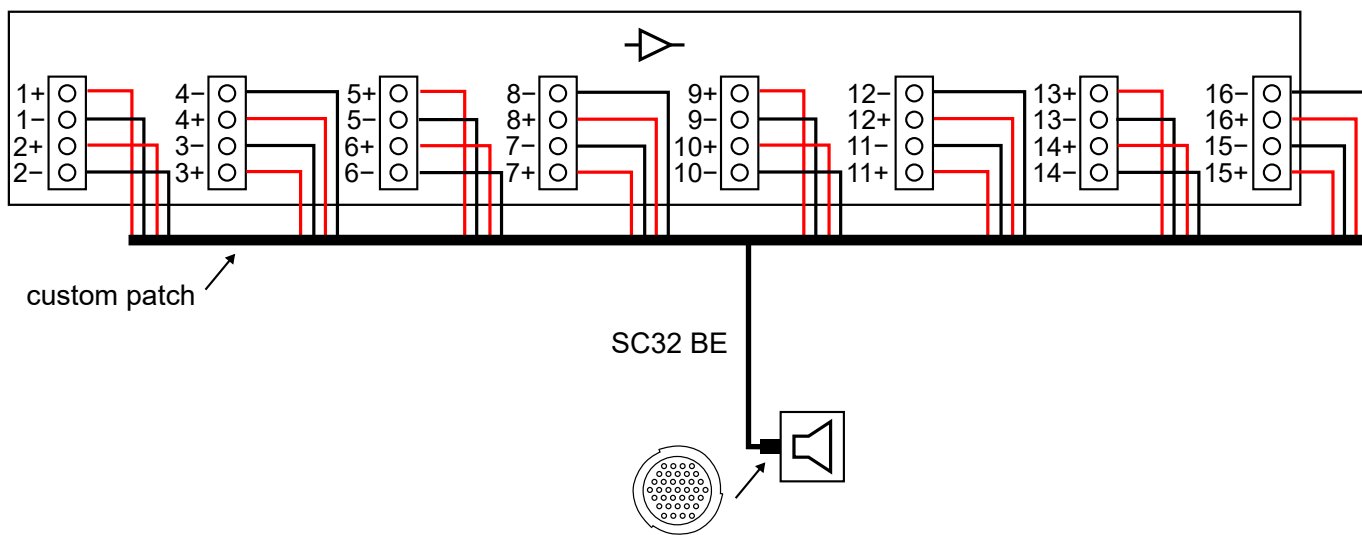

Recommendation for speaker cables



Cable quality and resistance

Only use high-quality fully insulated loudspeaker cables made of stranded copper wire.

Use cables with a gauge offering low resistance per unit length and keep the cables as short as possible.

It is good practice to keep loudspeaker cables short to ensure optimal system performance. L-Acoustics strongly recommends using cables of similar type, length, and gauge to address symmetrical deployment of loudspeakers, such as stereo systems, L-ISA frontal systems, or outfill systems.



For more information about cable effect on loudspeaker frequency response, refer to the publication **Demystifying the effects of loudspeaker cables** on the L-Acoustics website, in **Education > Scientific resources > Scientific publications**.

Refer to the following table for recommended cable length for uncompromised performance.

cable gauge			recommended maximum length					
			8 Ω load		4 Ω load		2.7 Ω load	
mm ²	SWG	AWG	m	ft	m	ft	m	ft
1.5	18	16	18	60	9	30	–	–
2.5	15	14	30	100	15	50	10	33
4	13	11	50	160	25	80	17	53
6	11	9	74	240	37	120	25	80

Use the more detailed L-Acoustics calculation tool to evaluate cable length and gauge based on the type and number of loudspeakers connected. The calculation tool is available on our website: <https://www.l-acoustics.com/installation-tools/>